



INTERNATIONAL SHIP CLASSIFICATION

**GUIDELINES ON CALCULATION AND
VERIFICATION OF THE ATTAINED
ENERGY EFFICIENCY EXISTING SHIP
INDEX (EEXI)**

2022

Effective from 1 December 2022

CONTENTS

CHAPTER 1 GENERAL	1
1.1 General requirements	1
1.2 Scope of application	1
1.3 Definitions ...	2
1.4 EEXI verification process	4
CHAPTER 2 CALCULATION OF THE ATTAINED EEXI	5
2.1 Attained EEXI calculation formula	5
2.2 Method of selecting parameters of the Attained EEXI formula	5
CHAPTER 3 VERIFICATION OF THE ATTAINED EEXI	11
3.1 General requirements	11
3.2 Requirements for information submission	11
3.3 Requirements for survey and verification	12
3.4 Verification of the attained EEXI in case of major conversion	13
APPENDIX 1 SAMPLE OF EEXI TECHNICAL FILE	15
APPENDIX 2 CALCULATION OF THE ATTAINED EEXI OF LNG CARRIERS	21
APPENDIX 3 GUIDANCE ON METHODS, PROCEDURES AND VERIFICATION OF IN-SERVICE PERFORMANCE MEASUREMENTS	24
APPENDIX 4 VERIFICATION OF NUMERICAL CALCULATIONS	36

CHAPTER 1 GENERAL

1.1 General requirements

1.1.1 The Guidelines are intended to provide guidance to the calculation and verification of the Attained Energy Efficiency Existing Ship Index (EEXI).

1.1.2 In accordance with MARPOL Annex VI, the verification of the ship's attained EEXI is to take place at the first annual, intermediate or renewal survey of the International Air Pollution Prevention (IAPP) certificate or the initial survey of the International Energy Efficiency (IEE) certificate, whichever is the first, on or after 1 January 2023, so as to renew/issue the IEE certificate at corresponding surveys. For ships undergoing a major conversion to which the EEXI requirements are applicable, the ship's Attained EEXI is to be verified and the IEE certificate is to be renewed after completion of the major conversion.

1.1.3 For ships with the Attained EEDI, if the Attained EEDI has already complied with the requirements for Required EEXI, the Attained EEDI may be verified as the ship's Attained EEXI. In this case, the Attained EEXI may be verified based on the EEDI technical file. This paragraph is not applicable to pre-EEDI ships which have Statement of Voluntary Compliance (SOVC) or EEDI ships which have only Preliminary Approved EEDI technical file.

1.1.4 For ships complying with the definition of LNG carrier in 1.3.1(12) of the Guidelines, its Required EEXI is to be calculated based on LNG carrier, regardless of whether its EEDI calculation and verification have been carried out based on gas carrier.

1.1.5 Energy efficiency technical measures adopted by existing ships to comply with Required EEXI are to be completed before EEXI verification, subject to survey and confirmation by ISC.

1.2 Scope of application

1.2.1 The Guidelines are applicable to the following ships of 400 gross tonnage and above:

- (1) Bulk carrier;
- (2) Gas carrier;
- (3) Tanker;
- (4) Containership;
- (5) General cargo ship;
- (6) Refrigerated cargo carrier;
- (7) Combination carrier;
- (8) LNG carrier;
- (9) Ro-ro passenger ship;
- (10) Ro-ro cargo ship (vehicle carrier);
- (11) Ro-ro cargo ship;
- (12) Cruise passenger ship having non-conventional propulsion.

1.2.2 The Guidelines are not applicable to ships having non-conventional propulsion listed in 1.2.1 other than cruise passenger ship having non-conventional propulsion and LNG carrier.

1.2.3 The Guidelines are not applicable to ships complying with the definition of category A ship in 1.3.1(14), which are listed in 1.2.1.

1.3 Definitions

1.3.1 Definitions of ship types

- (1) *Bulk carrier* means a ship which is intended primarily to carry dry cargo in bulk, including such types as ore carriers as defined in SOLAS Regulation XII/1, but excluding combination carriers.
 - (2) *Gas carrier* means a cargo ship, other than an LNG carrier, constructed or adapted and used for the carriage in bulk of any liquefied gas.
 - (3) *Tanker* means an oil tanker as defined in MARPOL Annex I, regulation 1 or a chemical tanker or a NLS (noxious liquid substance) tanker as defined in MARPOL Annex II, regulation 1.
 - (4) *Container ship* means a ship designed exclusively for the carriage of containers in holds and on deck.
 - (5) *General cargo ship* means a ship with a multi-deck or single deck hull designed primarily for the carriage of general cargo. This definition excludes specialized dry cargo ships, which are not included in the calculation of reference lines for general cargo ships, namely livestock carrier, barge carrier, heavy load carrier^①, yacht carrier, nuclear fuel carrier.
 - (6) *Refrigerated cargo carrier* means a ship designed exclusively for the carriage of refrigerated cargoes in holds.
 - (7) *Combination carrier* means a ship designed to load 100% deadweight with both liquid and dry cargo in bulk.
 - (8) *Passenger ship* means a ship which carries more than 12 passengers.
 - (9) *Ro-ro passenger ship* means a passenger ship with roll-on-roll-off cargo spaces.
 - (10) *Ro-ro cargo ship (vehicle carrier)* means a multi deck roll-on-roll-off cargo ship designed for the carriage of empty cars and trucks.
 - (11) *Ro-ro cargo ship* means a ship designed for the carriage of roll-on-roll-off cargo transportation units.
 - (12) *LNG carrier* means a cargo ship constructed or adapted and used for the carriage in bulk of liquefied natural gas (LNG).
 - (13) *Cruise passenger ship* means a passenger ship not having a cargo deck, designed exclusively for commercial transportation of passengers in overnight accommodations on a sea voyage.
 - (14) *Category A ship* means a ship designed for operation in polar waters in at least medium first-year ice, which may include old ice inclusions, as defined in the Polar Code^②.
- 1.3.2 *Conventional propulsion* means a method of propulsion where a main reciprocating internal combustion engine(s) is the prime mover and coupled to a propulsion shaft either directly or through a gear box.
- 1.3.3 *Non-conventional propulsion* means a method of propulsion, other than conventional propulsion, including diesel-electric propulsion, turbine propulsion, and hybrid propulsion systems.
- 1.3.4 *Attained EEDI* means the EEDI value achieved by an individual ship.
- 1.3.5 *Required EEDI* means the maximum value of the Attained EEDI permissible for a specific ship type and size.
- 1.3.6 *Attained EEXI* means the EEXI value achieved by an individual ship.
- 1.3.7 *Required EEXI* means the maximum value of the Attained EEXI permissible for a specific ship type and size.
- 1.3.8 *Tank test* means model towing tests, model self-propulsion tests and model propeller open water tests.
- 1.3.9 *Numerical Calculations* are understood as being computer aided calculations in which equations are resolved by Computational Fluid Dynamics solvers/software, considering the effect of viscosity on

① For the scope of definition of heavy load carrier, reference may be made to IACS Rec.170.

② The International Code for Ships Operating in Polar Waters adopted by resolutions MSC.385(94) and MEPC.264(68).

calculation accuracy. Numerical calculations may be accepted as equivalent to model propeller open water tests or used to complement the tank tests conducted (e.g. to evaluate the effect of additional hull features such as fins, etc. on ships' performance), or as a replacement for model tests provided that the methodology and numerical model used have been validated/calibrated against parent hull sea trials and/or model tests, with the approval of the verifier.

1.3.10 *Comparable ship* means a ship of which hull form (expressed in the lines such as sheer plan and body plan) excluding additional hull features such as fins and of which principal particulars are identical to that of the parent ship.

1.3.11 *Similar ship* is a vessel with the same ship type as defined in paragraph 1.3.1, same number of shafts/propellers, within a threshold of 5% difference in terms of LPP , C_b , displacement at Maximum Summer Load Draught, with similar bow shape (bulbous bow, integrated bulbous bow, straight bow, etc.) and similar stern hull shape and arrangement with appendages.

1.3.12 *Calibration factor* is defined as the ratio between the power achieved through sea trial and/or model tests and the numerical calculation at the same speed.

1.3.13 *Deadweight (DWT)* means the difference in tonnes between the displacement of a ship in water of a relative density of 1025kg/m^3 at the summer loadline draught and the lightweight of the ship. Unless otherwise specified by the Administration, the summer loadline draught is taken as the maximum summer draught in the supplement to the IEE certificate.

1.3.14 *A sister ship* is one built in a series by same shipyard with identical main dimensions, body lines, appendages, and propulsion system.

1.3.15 *Power limitation* means a verified and approved operation for the limitation of the maximum shaft power or the maximum power of engine by technical means, consisting of overridable power limitation and non-overridable power limitation. Overridable power limitation means the limitation of maximum power can be temporarily overridden by the ship master or the officer in charge of navigational watch (OICNW) for the purpose of securing the safety of a ship or saving life at sea.

1.3.16 *Power reduction modification* means the modification that optimizes and adjusts the main propulsion units (including main engine, transmission device, propeller, etc.) in order to reduce maximum output power of engine, consisting of overridable power reduction modification and non-overridable power reduction modification. Overridable power reduction modification means the output power limitation due to the modification can be temporarily overridden by the ship master or the officer in charge of navigational watch (OICNW) for the purpose of securing the safety of a ship or saving life at sea.

1.3.17 *Major conversion* means a conversion of a ship to which the Guidelines apply:

- (1) which substantially alters the dimensions, carrying capacity or engine power of the ship; or
- (2) which changes the type of the ship; or
- (3) the intent of which is substantially to prolong the life of the ship; or
- (4) which otherwise so alters the ship that it is a new ship; or
- (5) which substantially alters the energy efficiency of the ship and cause the ship to exceed the applicable Required EEXI as set out in MARPOL Annex VI.

1.3.18 *Verifier* means an Administration, or organization duly authorized by it, which conducts the survey and certification of the EEXI, which is ISC in the context of the Guidelines, unless otherwise provided.

1.3.19 Definitions of parameters related to the calculation of Attained EEXI may refer to ISC Guidelines on Calculation and Verification of Energy Efficiency Design Index (EEDI) of Sea-going Ships Engaged on International Voyages.

1.4 EEXI verification process

1.4.1 The submitter may submit the ship's EEXI verification application to ISC survey unit, together with the EEXI technical file (at least in English) and relevant information. ISC will complete the issuance/renewal of IEE certificate of classed ships at the first annual, intermediate or renewal survey of the IAPP certificate or at the initial survey of the IEE certificate, whichever is the first, on or after 1 January 2023.

1.4.2 For ships that adopt power limitation/power reduction modification to meet EEXI requirements, technical documents related to power limitation/power reduction modification issued by the main engine manufacturer or professional organizations are to be provided. For ships that adopt overridable power limitation/power reduction modification, the Onboard Management Manual (OMM) of power limitation/power reduction modification is also to be provided. The submitter may apply for on-site verification of the power limitation/power reduction system after the EEXI technical file has been approved. This verification can be performed in conjunction with the IEE certificate renewal. OMM can be approved in accordance with relevant requirements in ISC Guidelines for Survey of Reducing Ship Power.

1.4.3 Where the Attained EEDI of a ship meets the Required EEXI, the submitter can apply to the ISC survey unit for an IEE certificate renewal after completing the EEDI technical file verification. It can also apply to the ISC survey unit for an IEE certificate renewal in conjunction with the first annual, intermediate or renewal survey of the IAPP certificate, whichever is the first, on or after 1 January 2023. For ships complying with EEXI requirements upon survey and verification, ISC survey unit may issue Statements of Compliance related to EEXI to the ship upon request by the submitter before 1 January 2023.

1.4.4 The verification process of ship's Attained EEXI is shown in Figure 1.1.

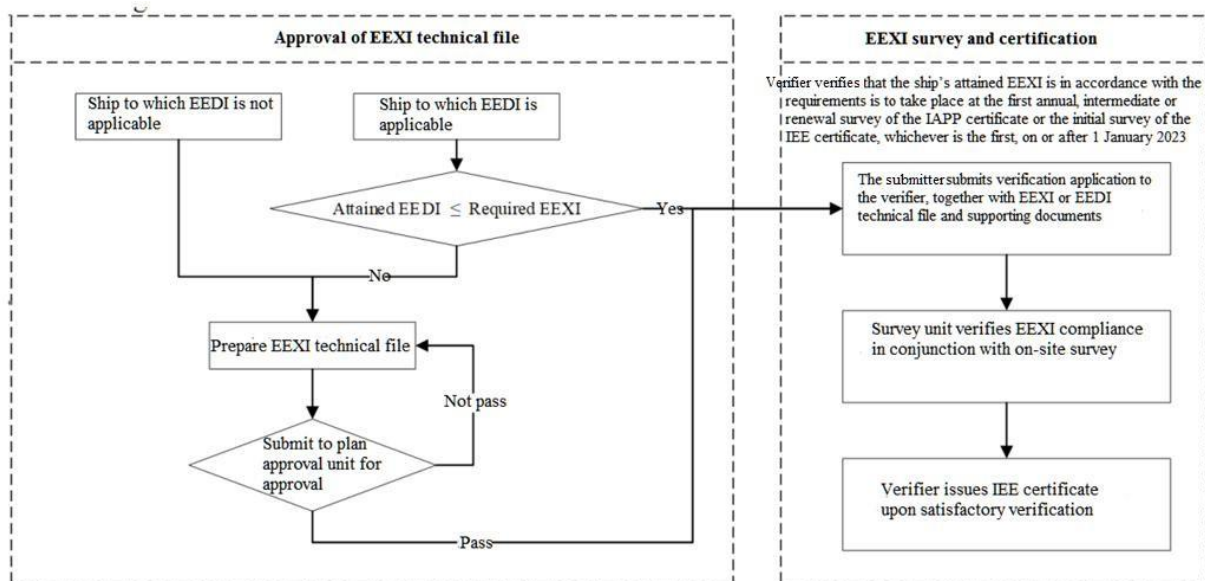

Figure 1.1 Verification Process of Attained EEXI

CHAPTER 2 CALCULATION OF THE ATTAINED EEXI

2.1 Attained EEXI calculation formula

2.1.1 The attained Energy Efficiency Existing Ship Index (EEXI) is calculated by the following formula:

$$\frac{\left(\prod_{j=1}^n f_j \right) \left(\sum_{i=1}^{nME} P_{ME(i)} \cdot C_{FME(i)} \cdot SFC_{ME(i)} \right) + \left(P_{AE} \cdot C_{FAE} \cdot SFC_{AE} \right) + \left(\prod_{j=1}^n f_j \cdot \sum_{i=1}^{nPTI} P_{PTI(i)} - \sum_{i=1}^{neff} f_{eff(i)} \cdot P_{AE,eff(i)} \right) C_{FAE} \cdot SFC_{AE}}{f_i \cdot f_c \cdot f_l \cdot Capacity \cdot f_w \cdot V_{ref} \cdot f_m} - \left(\sum_{i=1}^{neff} f_{eff(i)} \cdot P_{eff(i)} \cdot C_{FME} \cdot SFC_{ME} \right)$$

* If part of the Normal Maximum Sea Load is provided by shaft generators, SFC_{ME} and C_{FME} may – for that part of the power – be used instead of SFC_{AE} and C_{FAE} .

** In case of $P_{PTI(i)} > 0$, the average weighted value of $(SFC_{ME} \cdot C_{FME})$ and $(SFC_{AE} \cdot C_{FAE})$ to be used for calculation of P_{eff} .

2.2 Method of selecting parameters of the Attained EEXI formula

2.2.1 For calculation of the attained EEXI by the formula in paragraph 2.1, parameters under ISC Guidelines on Calculation and Verification of Energy Efficiency Design Index (EEDI) of Sea-going Ships Engaged on International Voyages apply, unless expressly provided otherwise. In referring to the aforementioned guidelines, the terminology “EEDI” is to be read as “EEXI”.

2.2.2 For ships using innovative energy efficiency technologies, the Attained EEXI are to be calculated in accordance with 2021 Guidance on treatment of innovative energy efficiency technologies for calculation and verification of the attained EEDI and EEXI (MEPC.1/Circ.896).

2.2.3 Power of main engines ($P_{ME(i)}$)

(1) In cases where overridable power limitation/power reduction modification is installed, $P_{ME(i)}$ is 83% of the limited installed power (MCR_{lim}) or 75% of the original installed power (MCR), whichever is lower, for each main engine (i). In cases where non-overridable power limitation/power reduction modification is installed, $P_{ME(i)}$ is 75% of the limited installed power (MCR_{lim}), for each main engine (i).

(2) In cases where the power limitation/power reduction modification and shaft generator(s) are installed, $\sum P_{ME(i)}$ is calculated by the following formula:

$$\sum_{i=1}^{nME} P_{ME(i)} = 0.75 \times (\sum MCR_{lim(i)} - \sum P_{PTO(i)}) \text{ and } 0.75 \times \sum P_{PTO(i)} \leq P_{AE}$$

(3) For LNG carriers having steam turbine propulsion, $P_{ME(i)}$ is 83% of the limited installed power (MCR_{lim}) for each main engine (i). For LNG carriers having diesel electric propulsion, $P_{ME(i)}$ is 83% of the limited installed power (MPP_{lim}), divided by the electrical efficiency, for each main engine (i). For LNG carriers, the power from combustion of the excessive natural boil-off gas in the engines or boilers to avoid releasing to the atmosphere or unnecessary thermal oxidation should be deducted from $P_{ME(i)}$ with the approval of the verifier. The recommended method of deduction is given in Appendix 2.

2.2.4 Power of auxiliary engines ($P_{AE(i)}$)

(1) In cases where non-overridable power limitation/power reduction modification except for propeller retrofit is installed, when the power of auxiliary engines (P_{AE}) is calculated by the formula given in paragraph 2.3.5.5 of ISC Guidelines on Calculation and Verification of Energy Efficiency Design Index (EEDI) of Sea-going Ships Engaged on International Voyages, “ MCR_{ME} ” is to be read as “ MCR_{lim} ”. In cases where other type of power limitation/power reduction modification is installed, when the power of auxiliary

engines (P_{AE}) is calculated by the formula given in paragraph 2.3.5.5 of ISC Guidelines on Calculation and Verification of Energy Efficiency Design Index (EEDI) of Sea-going Ships Engaged on International Voyages, “ MCR_{ME} ” is still taken as the rated power of main engine. In cases where both types of modification above are installed, P_{AE} may be taken as the lower value.

(2) For ships where power of auxiliary engines (P_{AE}) value calculated by the formula in paragraph 2.3.5.5 of ISC Guidelines on Calculation and Verification of Energy Efficiency Design Index (EEDI) of Sea-going Ships Engaged on International Voyages is significantly different from the total power used at normal seagoing, e.g. in cases of passenger ships, and where the electric power table is not available, the P_{AE} value may be approximated either by:

- ① annual average figure of P_{AE} at sea from onboard monitoring obtained prior to the EEXI certification;
- ② for cruise passenger ships, approximated value of power of auxiliary engines ($P_{AE,app}$), as defined below:

$$P_{AE,app} = 0.1193 \times GT + 1814.4 \quad [kW]$$

- ③ for ro-ro passenger ships, approximated value of power of auxiliary engines ($P_{AE,app}$), as defined below:

$$P_{AE,app} = 0.866 \times GT^{0.732} \quad [kW]$$

2.2.5 Ship speed (V_{ref})

(1) For ships falling into the scope of the EEDI requirement, the ship speed V_{ref} is to be obtained from an approved speed-power curve in the ship’s EEDI technical file.

(2) For ships not falling into the scope of the EEDI requirement, the ship speed V_{ref} is to be obtained from a speed-power curve (including those obtained by model test and/or sea trial) which is obtained by a method complying with the verification requirements in ISC Guidelines on Calculation and Verification of Energy Efficiency Design Index (EEDI) of Sea-going Ships Engaged on International Voyages.

(3) For ships not falling into the scope of the EEDI requirement but whose sea trial results, which may have been calibrated by the tank test, under the EEDI draught and the sea condition as specified in paragraph 2.3.2 of ISC Guidelines on Calculation and Verification of Energy Efficiency Design Index (EEDI) of Sea-going Ships Engaged on International Voyages are included in the sea trial report, the ship speed V_{ref} may be calculated from the data in the sea trial report using the following formula:

$$V_{ref} = V_{S,EEDI} \times \left[\frac{P_{ME}}{P_{S,EEDI}} \right]^{\frac{1}{3}} \quad [knot]$$

where: $V_{S,EEDI}$ —the sea trial service speed under the EEDI draught;

$P_{S,EEDI}$ —the power of the main engine corresponding to $V_{S,EEDI}$.

(4) For containerships, bulk carriers or tankers not falling into the scope of the EEDI requirement but whose sea trial results, which may have been calibrated by the tank test, under the design load draught and sea condition as specified in paragraph 2.3.2 of ISC Guidelines on Calculation and Verification of Energy Efficiency Design Index (EEDI) of Sea-going Ships Engaged on International Voyages are included in the sea trial report, the ship speed V_{ref} may be calculated from the data in the sea trial report using the following formula:

$$V_{ref} = k^{\frac{1}{3}} \times \left(\frac{DWT_{S,service}}{Capacity} \right)^{\frac{2}{9}} \times V_{S,service} \times \left[\frac{P_{ME}}{P_{S,service}} \right]^{\frac{1}{3}} \quad [knot]$$

where: $V_{S,service}$ —the sea trial service speed under the design load draught;
 $DWT_{S,service}$ —the deadweight under the design load draught;
 $P_{S,service}$ —the power of the main engine corresponding to $V_{S,service}$;
 k —the scale coefficient, which is taken in accordance with Table 2.1.

Scale coefficient k

Table 2.1

Ship type	k
Containerships (DWT≤120,000)	0.95
Containerships (DWT>120,000)	0.93
Bulk carrier (DWT≤200,000)	0.97
Bulk carrier (DWT>200,000)	1.00
Tanker (DWT≤100,000)	0.97
Tanker (DWT>100,000)	1.00

(5) In cases where the speed-power curve is not available or the sea trial report does not contain the EEDI or design load draught condition, the ship speed V_{ref} can be obtained from the in-service performance measurement method conducted and verified in accordance with the methods and procedures as specified in the Appendix 3.

(6) In cases where the speed-power curve is not available or the sea trial report does not contain the EEDI or design load draught condition, the ship speed V_{ref} can also be approximated by $V_{ref,app}$, to be calculated as follows:

$$V_{ref,app} = (V_{ref,avg} - m_V) \times \left[\frac{\sum P_{ME}}{0.75 \times MCR_{avg}} \right]^{\frac{1}{3}} \quad [knot]$$

For LNG carriers having diesel electric propulsion system and cruise passenger ships having non-conventional propulsion, the ship speed V_{ref} can be approximated by $V_{ref,app}$, to be calculated as follows:

$$V_{ref,app} = (V_{ref,avg} - m_V) \times \left[\frac{\sum MPP_{Motor}}{MPP_{avg}} \right]^{\frac{1}{3}} \quad [knot]$$

For LNG carriers having steam turbine propulsion system, the ship speed V_{ref} can be approximated by $V_{ref,app}$, to be calculated as follows:

$$V_{ref,app} = (V_{ref,avg} - m_V) \times \left[\frac{\sum MCR_{SteamTurbine}}{MCR_{avg}} \right]^{\frac{1}{3}} \quad [knot]$$

where: $V_{ref,avg}$ —a statistical mean of distribution of ship speed in given ship type and ship size, to be calculated as follows, where A , B and C are the parameters given in Table 2.2:

$$V_{ref,avg} = A \times B^C \quad [knot]$$

m_V —a performance margin of a ship, which should be 5% of $V_{ref,avg}$ or one knot, whichever is lower;

MCR_{avg} —a statistical mean of distribution of MCRs for main engines, to be calculated as

follows, where D , E and F are the parameters given in Table 2.3;

$$MCR_{avg} = D \times E^F \quad [kW]$$

MPP_{avg} —a statistical mean of distribution of MPPs for motors in given ship type and ship size, to be calculated as follows, where D , E and F are the parameters given in Table 2.3;

$$MPP_{avg} = D \times E^F \quad [kW]$$

In cases where power limitation/power reduction modification is installed, the ship speed V_{ref} approximated by $V_{ref,app}$ should be calculated as follows:

$$V_{ref,app} = (V_{ref,avg} - m_V) \times \left[\frac{\sum P_{ME}}{0.75 \times MCR_{avg}} \right]^{\frac{1}{3}} \quad [knot]$$

For LNG carriers having diesel electric propulsion system and cruise passenger ship having non-conventional propulsion, the ship speed V_{ref} approximated by $V_{ref,app}$ should be calculated as follows:

$$V_{ref,app} = (V_{ref,avg} - m_V) \times \left[\frac{\sum MPP_{lim}}{MPP_{avg}} \right]^{\frac{1}{3}} \quad [knot]$$

For LNG carriers having steam turbine propulsion system, in cases where power limitation/power reduction modification is installed, the ship speed V_{ref} approximated by $V_{ref,app}$ should be calculated as follows:

$$V_{ref,app} = (V_{ref,avg} - m_V) \times \left[\frac{\sum MCR_{lim}}{MCR_{avg}} \right]^{\frac{1}{3}} \quad [knot]$$

Parameters to calculate $V_{ref,avg}$

Table 2.2

Ship type	A	B	C
Bulk carrier	10.6585	DWT of the ship	0.02706
Gas carrier	7.4462	DWT of the ship	0.07604
Tanker	8.1358	DWT of the ship	0.05383
Containership	3.2395	DWT of the ship where DWT ≤ 80,000 80,000 where DWT > 80,000	0.18294
General cargo ship	2.4538	DWT of the ship	0.18832
Refrigerated cargo carrier	1.0600	DWT of the ship	0.31518
Combination carrier	8.1391	DWT of the ship	0.05378
LNG carrier	11.0536	DWT of the ship	0.05030
Ro-ro cargo ship (vehicle carrier)	16.6773	DWT of the ship	0.01802
Ro-ro cargo ship	8.0793	DWT of the ship	0.09123
Ro-ro passenger ship	4.1140	DWT of the ship	0.19863
Cruise passenger ship having non-conventional propulsion	5.1240	GT of the ship	0.12714

Parameters to calculate MCR_{avg} or MPP_{avg}

Table 2.3

Ship type	D	E	F
Bulk carrier	23.7510	DWT of the ship	0.54087
Gas carrier	21.4704	DWT of the ship	0.59522
Tanker	22.8415	DWT of the ship	0.55826
Containership	0.5042	DWT of the ship where $DWT \leq 95,000$ 95,000 where $DWT > 95,000$	1.03046
General cargo ship	0.8816	DWT of the ship	0.92050
Refrigerated cargo carrier	0.0272	DWT of the ship	1.38634
Combination carrier	22.8536	DWT of the ship	0.55820
LNG carrier	20.7096	DWT of the ship	0.63477
Ro-ro cargo ship (vehicle carrier)	262.7693	DWT of the ship	0.39973
Ro-ro cargo ship	37.7708	DWT of the ship	0.63450
Ro-ro passenger ship	9.1338	DWT of the ship	0.91116
Cruise passenger ship having non-conventional propulsion	1.3550	GT of the ship	0.88664

(7) In cases where the energy-saving device is installed to meet the requirements of EEXI, the effect of the device may be reflected in the ship speed V_{ref} with the approval of the verifier, based on at least one of the following methods: sea trials after installation of the device; and/or in-service performance measurement method; and/or dedicated model tests; and/or numerical calculations. For sister ships, the energy-saving effect of the same energy-saving device on one ship applies to other sister ships.

(8) For energy efficiency improvement achieved by the application of resistance reduction coating on the ship, the energy-saving effect can be obtained by sea trial.

2.2.6 Certified specific fuel consumption (SFC)

(1) In cases where power limitation/power reduction modification is installed, the SFC corresponding to the P_{ME} should be interpolated by using SFC s listed in an applicable test report included in an approved NO_x Technical File of the main engine.

(2) If no applicable report, the SFC specified by the manufacturer or confirmed by the verifier may be used.

(3) For those engines which do not have a test report included in the NO_x Technical File and which do not have the SFC specified by the manufacturer or confirmed by the verifier, the SFC can be approximated by SFC_{app} defined as follows:

$$SFC_{ME,app} = 190 [g/kWh]$$

$$SFC_{AE,app} = 215 [g/kWh]$$

2.2.7 Conversion factor between fuel consumption and CO₂ emission (C_F)

For those engines which do not have a test report included in the NO_x Technical File and which do not have the SFC specified by the manufacturer, the C_F corresponding to SFC_{app} should be defined as follows:

$$C_F = 3.114 [t \cdot CO_2 / t \cdot Fuel], \text{ for diesel ships (incl. HFO use in practice)}$$

2.2.8 Correction factor for ship specific design elements f_j

(1) Correction factor for ro-ro cargo and ro-ro passenger ships (f_{jRoRo})

For ro-ro cargo and ro-ro passenger ships, f_{jRoRo} is calculated as follows:

$$f_{jRoRo} = \frac{1}{F_{nL}^{\alpha} \cdot \left(\frac{L_{pp}}{B_s}\right)^{\beta} \cdot \left(\frac{B_s}{d_s}\right)^{\gamma} \cdot \left(\frac{L_{pp}}{\sqrt{V^{1/3}}}\right)^{\delta}} ; \text{ if } f_{jRoRo} > 1 \text{ then } f_j = 1$$

where the Froude number, F_{nL} , is defined as:

$$F_{nL} = \frac{0.5144 \cdot V_{ref,F}}{\sqrt{L_{pp} \cdot g}}$$

where: $V_{ref,F}$ — in cases where overridable power limitation/power reduction modification is installed, the ship speed corresponding to 75% of MCR_{ME} ; in cases where non-overridable power limitation/power reduction modification is installed, the ship speed corresponding to 75% of MCR_{lim} .

The exponents α , β , γ and δ are defined in Table 2.4:

Value of α , β , γ and δ

Table 2.4

Ship type	Exponent			
	α	β	γ	δ
Ro-ro cargo ship	2.00	0.50	0.75	1.00
Ro-ro passenger ship	2.50	0.75	0.75	1.00

(2) Power correction factor for ice-classed ships f_j

In cases where non-overridable power limitation/power reduction modification except for propeller retrofit is installed, when the power correction factor for ice-classed ships f_j is calculated by the method given in paragraph 2.3.8.2 of ISC Guidelines on Calculation and Verification of Energy Efficiency Design Index (EEDI) of Sea-going Ships Engaged on International Voyages, “ MCR_{ME} ” is to be read as “ MCR_{lim} ”. In cases where other type of power limitation/power reduction modification is installed, when the power correction factor for ice-classed ships f_j is calculated by the method given in paragraph 2.3.8.2 of ISC Guidelines on Calculation and Verification of Energy Efficiency Design Index (EEDI) of Sea-going Ships Engaged on International Voyages, “ MCR_{ME} ” is still taken as the rated power of main engine.

(3) Correction factor for general cargo ships f_j

In cases where power limitation/power reduction modification is installed, when the correction factor for general cargo ships f_j is calculated by the method given in paragraph 2.3.8.6 of ISC Guidelines on Calculation and Verification of Energy Efficiency Design Index (EEDI) of Sea-going Ships Engaged on International Voyages, “ V_{ref} ” is to be read as “ V_{ref} ” as defined in paragraph 2.2.5 of the Guidelines.

2.2.9 Cubic capacity correction factor for ro-ro cargo ships (vehicle carrier) ($f_{cVEHICLE}$)

For ro-ro cargo ships (vehicle carrier) having a DWT/GT ratio of less than 0.35, the following cubic capacity correction factor, $f_{cVEHICLE}$, should apply:

$$f_{cVEHICLE} = \left(\frac{(DWT/GT)}{0.35} \right)^{-0.8}$$

where: DWT — the deadweight tonnage;

GT — the gross tonnage in accordance with the International Convention of Tonnage Measurement of Ships 1969, annex I, regulation 3.

CHAPTER 3 VERIFICATION OF THE ATTAINED EEXI

3.1 General requirements

3.1.1 The 2021 Guidance on treatment of innovative energy efficiency technologies for calculation and verification of the attained EEDI and EEXI (MEPC.1/Circ.896) is to be applied for verification of Attained EEXI of ships adopting innovative energy efficiency technology.

3.1.2 The information used in the verification process may contain confidential information of submitters, which requires Intellectual Property Rights protection. In the case where the submitter wants a non-disclosure agreement with the verifier, the additional information is to be provided to the verifier upon mutually agreed terms and conditions.

3.2 Requirements for information submission

3.2.1 If the Attained EEDI of the ship satisfies the required EEXI, an application for a survey and documents proving that the Attained EEDI satisfies Required EEXI are to be submitted to a verifier. For ships the Attained EEDI of which can not satisfy the required EEXI or pre-EEDI ships, an application for a survey and an EEXI Technical File containing the necessary information for the verification and other relevant supporting documents (e.g.: NOx technical file, technical measures for power limitation, necessary sea trial report/model test report/numerical calculation report etc.) are to be submitted to a verifier.

3.2.2 The EEXI Technical File^① is to be written at least in English. The EEXI Technical File is to include, but not be limited to:

- (1) deadweight (*DWT*) or gross tonnage (*GT*) for ro-ro passenger ship and cruise passenger ship having non-conventional propulsion;
- (2) the rated installed power (*MCR*) of the main and auxiliary engines;
- (3) the limited installed power (*MCR_{lim}*) in cases where power limitation/power reduction modification is installed and the type of limitation (overridable limitation/non-overridable limitation due to propeller retrofit/other type of non-overridable limitation);
- (4) the ship speed (V_{ref});
- (5) the estimated approximate ship speed ($V_{ref,app}$) of pre-EEDI ship, where applicable;
- (6) an approved speed-power curve under the EEDI condition, which is described in the EEDI Technical File, where applicable;
- (7) an estimated speed-power curve under the EEDI condition, or under a different load draught to be calibrated to the EEDI condition, obtained from tank test and/or numerical calculations and/or sea trials and/or in service performance measurement, where applicable;
- (8) estimation process and methodology of the power curves, as necessary, including documentation on consistency with the defined quality standards (e.g. ITTC 7.5-03-01-02 and ITTC 7.5-03-01-04 in their latest revisions) and the verification of the numerical set-up with parent hull or the reference set of comparable ships in case of using numerical calculations;
- (9) a sea trial report and/or an in-service performance measurement report, where applicable;
- (10) calculation process of $V_{ref,app}$ for pre-EEDI ships, where applicable;
- (11) type of fuel;

① See Appendix 1 to the Guidelines for Sample of EEXI Technical File.

- (12) the specific fuel consumption (SFC) of the main and auxiliary engines;
- (13) the electric power table for certain ship types, where applicable;
- (14) the documented record of annual average figure of the auxiliary engine load at sea obtained prior to the date of application for a survey for verification of the ship's EEXI, where applicable;
- (15) calculation process of $P_{AE,app}$, where applicable;
- (16) principal particulars, ship type and the relevant information to classify the ship as such a ship type, and an overview of the propulsion system and electricity supply system on board;
- (17) description of energy-saving equipment, if available;
- (18) calculated value of the attained EEXI, including the calculation summary, which is to contain, at a minimum, each value of the calculation parameters and the calculation process used to determine the attained EEXI; and
- (19) for LNG carriers:
 - ① type and outline of propulsion systems (such as direct drive diesel, diesel electric, steam turbine);
 - ② LNG cargo tank capacity in m^3 and BOR as defined in ISC Guidelines on Calculation and Verification of Energy Efficiency Design Index (EEDI) of Sea-going Ships Engaged on International Voyages;
 - ③ shaft power of the propeller shaft after transmission gear at 100% of the rated output of motor (MPP_{Motor}) and $\eta(i)$ for diesel electric;
 - ④ shaft power of the propeller shaft after transmission gear at the de-rated output of motor ($MPP_{Motor,lim}$) in cases where power limitation/power reduction modification is installed;
 - ⑤ maximum continuous rated power ($MCR_{SteamTurbine}$) for steam turbine;
 - ⑥ limited maximum continuous rated power ($MCR_{SteamTurbine,lim}$) for steam turbine after power limitation/power reduction modification is installed; and
 - ⑦ $SFC_{SteamTurbine}$ for steam turbine. If the calculation is not available from the manufacturer, $SFC_{SteamTurbine}$ may be calculated by the submitter.

3.3 Requirements for survey and verification

3.3.1 The SFC is to be corrected to the value corresponding to the ISO standard reference conditions using the standard lower calorific value of the fuel oil, referring to ISO 15550:2002 and ISO 3046-1:2002. For the confirmation of the SFC, a copy of the approved NO_x Technical File and documented summary of the correction calculations are to be submitted to the verifier.

3.3.2 For ships equipped with dual-fuel engine(s) using LNG and fuel oil, the C_F -factor for gas (LNG) and the specific fuel consumption (SFC) of gas fuel is to be calculated according to 2.3.1 and 2.3.7 of ISC Guidelines on Calculation and Verification of Energy Efficiency Design Index (EEDI) of Sea-going Ships Engaged on International Voyages and verified according to 4.3.3 of the Guidelines.

3.3.3 In cases where power limitation/power reduction modification is installed, or in cases where engines do not have a test report included in the NO_x Technical File, SFC is to be calculated in accordance with paragraph 2.2.6 of the Guidelines. For this purpose, actual performance records of the engine may be used if satisfactory and acceptable to the verifier.

3.3.4 The verifier may request further information from the submitter, as specified in ISC Guidelines on Calculation and Verification of Energy Efficiency Design Index (EEDI) of Sea-going Ships Engaged on International Voyages, in addition to that contained in the EEXI Technical File, as necessary, to examine the calculation process of the attained EEXI. For ships the V_{ref} is obtained adopting or partially adopting numerical calculation, requirements for verification refer to Appendix 4 to the Guidelines.

3.3.5 In cases where the sea trial report as specified in paragraph 3.2.2(9) is submitted, the verifier is to request further information from the submitter to confirm that:

(1) the sea trial meets the conditions specified in 5.3.2(2), 5.3.2(3) and 5.3.2(6) of ISC Guidelines on Calculation and Verification of Energy Efficiency Design Index (EEDI) of Sea-going Ships Engaged on International Voyages;

(2) sea conditions were measured in accordance with ISO 15016:2002 or the equivalent if satisfactory and acceptable to the verifier;

(3) ship speed was measured in accordance with ISO 15016:2002 or the equivalent if satisfactory and acceptable to the verifier; and

(4) the measured ship speed was calibrated, if necessary, by taking into account the effects of wind, tide, waves, shallow water and displacement in accordance with ISO 15016:2002 or the equivalent which may be acceptable provided that the concept of the method is transparent for the verifier and publicly available/accessible.

3.3.6 For sea trials conducted after the entry into force of the Guidelines, see ISC Guidelines on Calculation and Verification of Energy Efficiency Design Index (EEDI) of Sea-going Ships Engaged on International Voyages for requirements for the sea trial and sea trial report.

3.3.7 For ships the EEXI ship speed of which is obtained by in-service performance measurement, the measurement and report are to be in accordance with Appendix 3 to the Guidelines.

3.3.8 The estimated speed-power curve obtained from the tank test and/or numerical calculations and/or the sea trial results or in-service performance measurement calibrated by the tank test is to be reviewed referring to ITTC 7.5-03-01-02 and ITTC 7.5-03-01-04 in their latest revisions.

3.3.9 In cases where the overridable power limitation/power reduction modification is adopted, the system is to be appropriately installed and/or sealed in accordance with ISC Guidelines for Surveys of Reducing Ship Power and a verified Onboard Management Manual (OMM) for overridable power limitation/power reduction modification is to be on board the ship.

3.3.10 In cases where power limitation/power reduction modification of ship is made while the change of NO_x key setting and/or component exceeds those specified in approved NO_x technical file of main engine, the main engine is to be re-certified.

3.3.11 In cases where non-overridable power limitation/power reduction modification is installed, it is to determine that propulsion power is sufficient to maintain the manoeuvrability of ships in adverse conditions after the power limitation/reduction according to the latest version of MEPC.1/Circ.850 Guidelines for determining minimum propulsion power to maintain the manoeuvrability of ships in adverse conditions.

3.3.12 Relevant surveys and tests after the power limitation/power reduction modification may be conducted by referring to ISC Guidelines for Survey of Reducing Ship Power.

3.3.13 Electric power table is to be validated separately according to ISC Guidelines on Calculation and Verification of Energy Efficiency Design Index (EEDI) of Sea-going Ships Engaged on International Voyages if used for calculating the power of auxiliary engines.

3.4 Verification of the attained EEXI in case of major conversion

3.4.1 In cases of a major conversion of a ship taking place at or after the completion date of the survey for EEXI verification, the submitter is to submit to a verifier an application for a general or partial survey with the EEXI Technical File duly revised, based on the conversion made and other relevant background documents.

3.4.2 The background documents are to include as a minimum, but are not limited to:

- (1) details of the conversion;
- (2) EEXI parameters changed after the conversion and the technical justifications for each respective parameter;
- (3) reasons for other changes made in the EEXI Technical File, if any; and
- (4) calculated value of the attained EEXI with the calculation summary, which is to contain, as a minimum, each value of the calculation parameters and the calculation process used to determine the attained EEXI after the conversion.

3.4.3 The verifier is to review the revised EEXI Technical File and other documents submitted and verify the calculation process of the attained EEXI to ensure that it is technically sound and reasonable and follows the Guidelines.

3.4.4 For verification of the attained EEXI after the major conversion, speed trials of the ship may be conducted, as necessary.

APPENDIX 1 SAMPLE OF EEXI TECHNICAL FILE

1 Data

1.1 General information

Shipowner	XXX Shipping Line
Shipbuilder	XXX Shipbuilding Company
Ship name	XXX
Hull No.	12345
IMO No.	94XXX12
Ship type	Bulk carrier

1.2 Principal particulars

Length overall	250.0 m
Length between perpendiculars	240.0 m
Breadth, moulded	40.0 m
Depth, moulded	20.0 m
Summer load line draught, moulded	14.0 m
Deadweight at summer load line draught	150,000t

1.3 Main engine

Manufacturer	XXX Industries
Type	6J70A
Maximum continuous rating (MCR_{ME})	15,000kW×80 rpm
Limited maximum continuous rating with the Engine Power Limitation installed ($MCR_{ME,lim}$)	9,940 kW ×70 rpm
Power limitation form	overridable
SFC of main engine	166.5 g/kWh
Number of sets	1
Fuel type	Diesel Oil

1.4 Auxiliary engine

Manufacturer	XXX Industries
Type	5J-200
Maximum continuous rating (MCR_{AE})	600kW×900rpm
SFC of auxiliary engine	220.0 g/kWh
Number of sets	3
Fuel type	Diesel Oil

1.5 Ship speed

Ship speed (V_{ref})	13.20kn
--------------------------	---------

2 Power curve

(Example 1; case of the EEDI ship)

An approved speed-power curve contained in the EEDI Technical File is shown in figure 2.1.

(Example 2; case of the pre-EEDI ship)

An estimated speed-power curve obtained from the tank test and/or numerical calculations, if available, is also shown in figure 2.1.

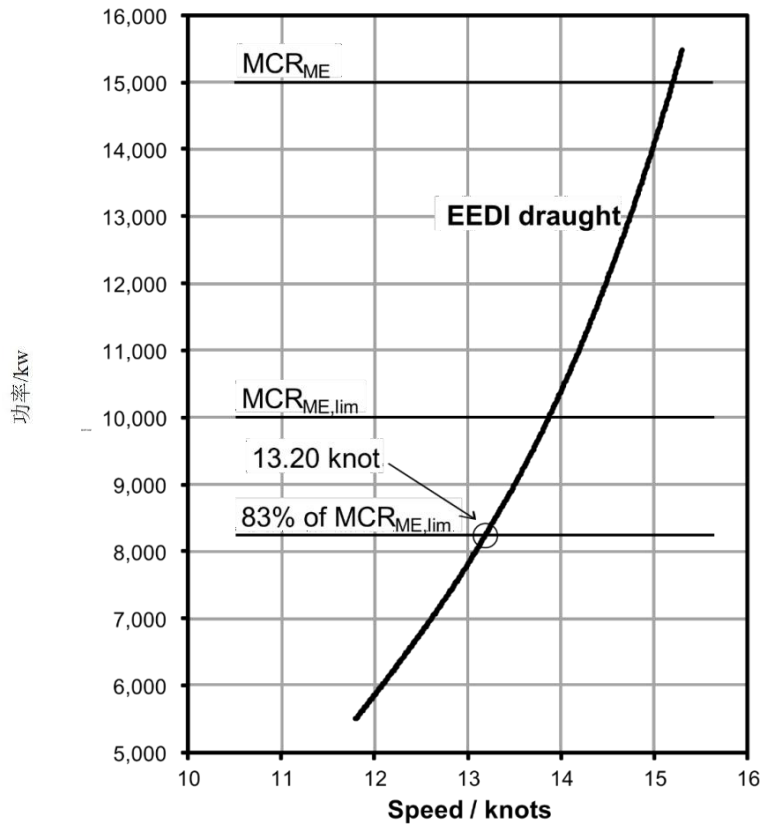

Figure 2.1: Power curve

(Example 3; case of the pre-EEDI ship with sea trial result calibrated to a different load draught)

An estimated speed-power curve under a ballast draught calibrated to the design load draught, obtained from the tank test and/or numerical calculations, if available, is shown in figure 2.2.

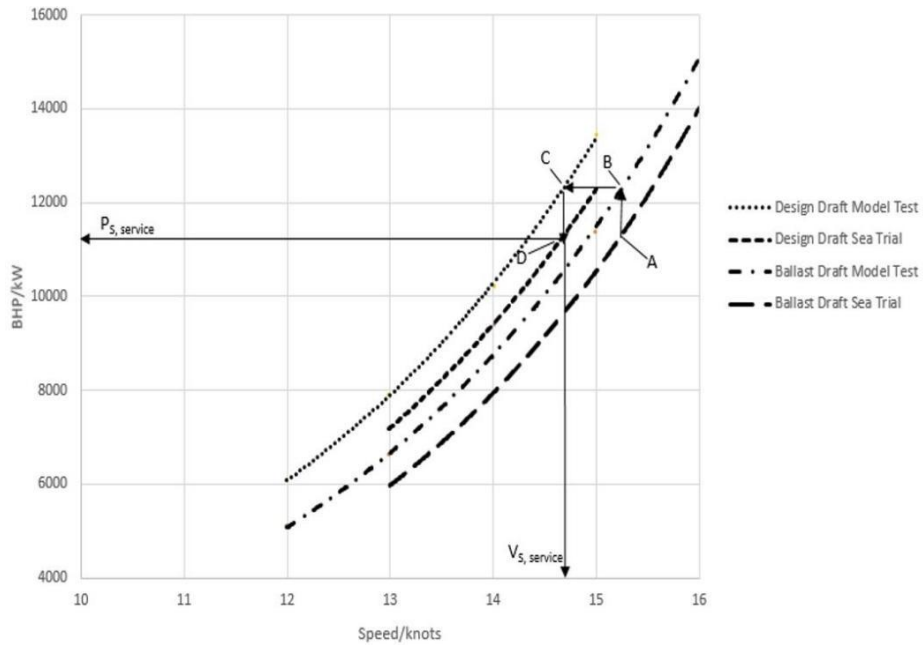

Figure 2.2: Power curve

3 Overview of propulsion system and electric power supply system

kn

3.1 Propulsion system

3.1.1 Main engine

Refer to paragraph 1.3 of this appendix.

3.1.2 Propeller

Type	Fixed pitch propeller
Diameter	7.0 m
Number of blades	4
Number of sets	1

3.2 Electric power supply system

3.2.1 Auxiliary engines

Refer to paragraph 1.4 of this appendix.

3.2.2 Main generators

Manufacturer	XXX Electric
Rated output	560 kW(700 kVA)×900 rpm
Voltage	AC 450V
Number of sets	3

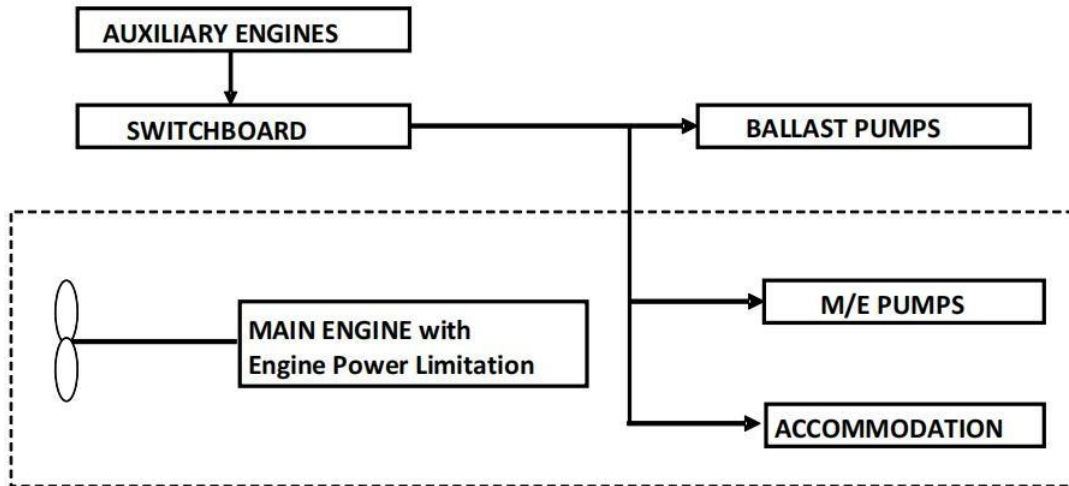

Figure 3.1: Schematic figure of propulsion and electric power supply system

4 Estimation process of speed-power curve

(Example: case of pre-EEDI ship)

Speed-power curve is estimated based on model test results and/or numerical calculations, if available. The flow of the estimation processes is shown below.

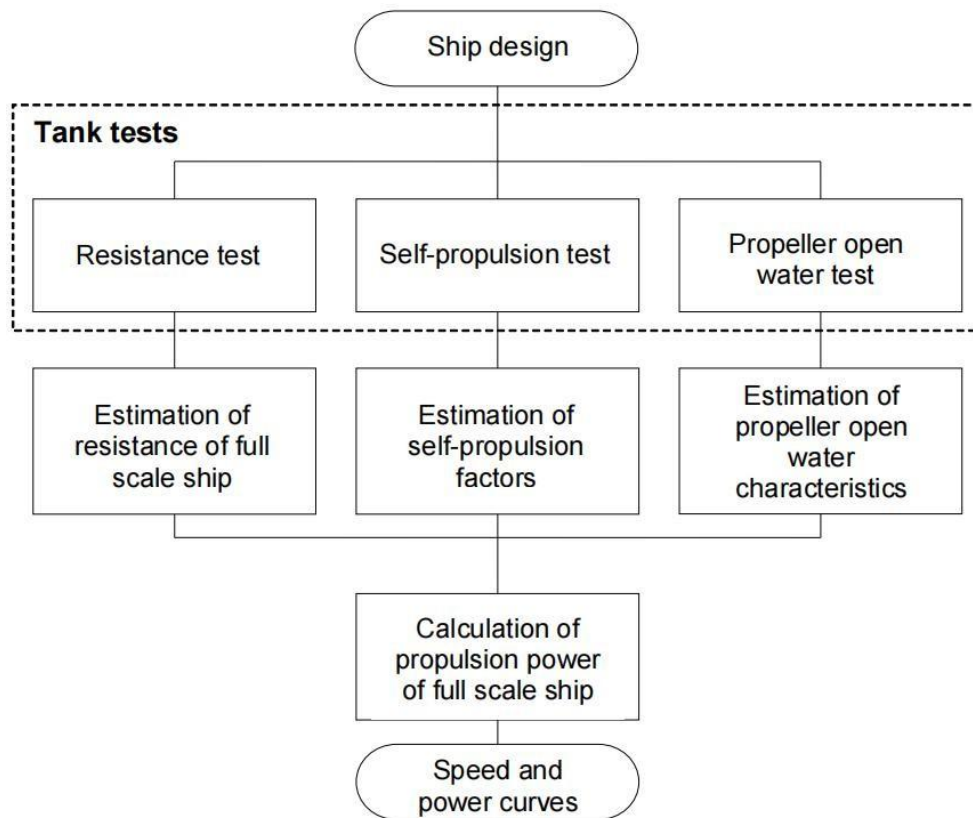

Figure 4: Flow chart of process for estimating speed-power curve from tank tests

5 Description of energy-saving equipment

5.1 Energy-saving equipment the effects of which are expressed as $P_{AEeff(i)}$ and/or $P_{eff(i)}$ in the EEXI calculation formula
(Example)

5.2 Other energy-saving equipment
(Example)

5.2.1 Rudder fins

5.2.2 Rudder bulb

.....

(Specifications, schematic figures and/or photos, etc. for each piece of equipment or device should be indicated. Alternatively, attachment of a commercial catalogue may be acceptable.)

6 Calculated value of attained EEXI

6.1 Basic data

Type of ship	Capacity DWT	Speed V_{ref} (kn)
Bulk carrier	150,000	13.20

6.2 Main engine

MCR_{ME} (kW)	$MCR_{ME,lim}$ (kW)	P_{ME} (kW)	Type of fuel	C_{FME}	SFC_{ME} (g/kWh)
15,000	9,940	8,250	Diesel oil	3.206	166.5

6.3 Auxiliary engines

P_{AE} (kW)	Type of fuel	C_{FAE}	SFC_{AE} (g/kWh)
625	Diesel oil	3.206	220.0

6.4 Ice class

N/A

6.5 Innovative electrical energy-efficient technology

N/A

6.6 Innovative mechanical energy-efficient technology

N/A

6.7 Cubic capacity correction factor

N/A

6.8 Calculated value of attained EEXI

$$EEXI = \frac{\left(\prod_{j=1}^M f_j\right) \left(\sum_{i=1}^{nME} P_{ME(i)} \cdot C_{FME(i)} \cdot SFC_{ME(i)}\right) + (P_{AE} \cdot C_{FAE} \cdot SFC_{AE})}{f_i \cdot f_c \cdot f_l \cdot Capacity \cdot f_w \cdot V_{ref} \cdot f_m} + \frac{\left\{\left(\prod_{j=1}^M f_j \cdot \sum_{i=1}^{nPTI} P_{PTI(i)} - \sum_{i=1}^{neff} f_{eff(i)} \cdot P_{AEeff(i)}\right) \cdot C_{FAE} \cdot SFC_{AE}\right\}}{f_i \cdot f_c \cdot f_l \cdot Capacity \cdot f_w \cdot V_{ref} \cdot f_m}$$

$$\begin{aligned}
& - \frac{(\sum_{i=1}^{neff} f_{eff(i)} \cdot P_{eff(i)} \cdot C_{FME} \cdot SFC_{ME})}{f_i \cdot f_c \cdot f_l \cdot Capacity \cdot f_w \cdot V_{ref} \cdot f_m} \\
& = \frac{1 \times (8250 \times 3.206 \times 166.5) + (625 \times 3.206 \times 220.0) + 0 - 0}{1 \times 1 \times 1 \times 150000 \times 1 \times 13.20 \times 1} \\
& = 2.45 \text{ (g - CO}_2\text{/ton} \cdot \text{n} \cdot \text{mile)}
\end{aligned}$$

Attained EEXI: 2.45g-CO₂/t*nm

APPENDIX 2 CALCULATION OF THE ATTAINED EEXI OF LNG CARRIERS

1 Calculation of steam turbine LNG carriers

The formula for the Attained EEXI for steam turbine LNG carriers is as follows:

$$\text{Attained EEXI} = \frac{P_{ME} \times SGC \times C_{F,LNG}}{\text{Capacity} \times V_{ref}}$$

In case of power limitation and after deduction of the power from combustion of excessive natural boil-off gas, the formula changes as follows (The methodology can only be applied to power limitation cases):

$$\text{Attained EEXI} = \frac{P_{ME_revised} \times SGC(P_{ME_lim}) \times C_{F,LNG}}{\text{Capacity} \times V_{ref}(P_{ME_lim})}$$

where:

MCR — Maximum Continuous Rating of main engine, in kW;

MCR_{lim} — limited installed power of main engine, in kW. The calculation of MCR_{lim} is an iterative process, as a reduction factor R_f is to be applied until Attained EEXI is less than or equal to Required EEXI. The relationship between MCR_{lim} and MCR is as follows:

$$MCR_{lim} = R_f \times MCR$$

where: R_f is reduction factor, $R_f < 1$;

P_{ME} — $0.83 MCR$;

P_{ME_lim} — $0.83 MCR_{lim}$;

V_{ref} —reference speed, in kn;

$Capacity$ — in t;

$C_{F,LNG}$ —carbon conversion factor of LNG, to be taken as 2.750 t CO₂/t Fuel;

SFC —certified specific fuel consumption, in g/kWh;

SGC —Specific gas consumption, in g/kWh, the result of SFC's correction to the value of LNG using the standard lower calorific value of the LNG (48,000 kJ/kg) at SNAME Condition (condition standard: air temperature 24 °C, inlet temperature of fan 38 °C, sea water temperature 24 °C). The conversion formula is as follows:

$$SGC = SFC \times \left(\frac{LCV_{(Fuel\ Oil)}}{LCV_{(LNG)}} \right)$$

where: LCV_{LNG} and $LCV_{Fuel\ Oil}$ are lower calorific value of LNG and fuel oil respectively, as specified in CCS Guidelines on Calculation and Verification of Energy Efficiency Design Index (EEDI) of Sea-going Ships Engaged on International Voyages.

In case the gas consumption is available at the Steam Heat Balance & Flow Diagram drawing (3 or more load points), then these values are to be used.

$P_{ME_revised}$ —the relevant power value after deduction of $P_{Excessive}$, in kW, to be calculated as follow:

$$P_{ME_revised} = 0.83MCR_{lim} - P_{Excessive}$$

$P_{Excessive}$ —the excessive power from combustion of excessive natural boil-off gas, in kW, to be calculated as follow:

$$P_{Excessive} = P_{BOG} - MCR_{lim}$$

P_{BOG} —the nominal power generated by consuming all boil-off gas from the cargo tanks, in kW, which may be determined in accordance with daily boil-off rate (BOR_{LNG}) and inputs from the ship's Steam Heat Balance and Flow Diagram.

BOR_{LNG} —Daily boil-off rate, in t/day, to be calculated as follow:

$$BOR_{LNG} = 0.000864 \times V_{Cargo}$$

where: V_{Cargo} — Cargo Tank Volume to be taken as the 100% net volume, in m^3 .

Steam Heat Balance and Flow Diagram provides the Fuel Oil Consumption at Different Power Levels in kg/h (minimum 4 points) or the corresponding fuel oil rate in g/kWh. The Fuel Oil Consumption is converted to Daily LNG Consumption using the ratio of the Lower Calorific values as stated by ISC Guidelines on Calculation and Verification of Energy Efficiency Design Index (EEDI) of Sea-going Ships Engaged on International Voyages.

Daily LNG consumption (tons LNG/day) is calculated at the different power levels as follows:

$$LNG \text{ Consumption} = \frac{\text{Fuel Oil Consumption} \left(\frac{kg}{h} \right) \times 24}{1000} \times \frac{LCV_{FO}}{LCV_{LNG}} \quad \left(\frac{tons}{day} \right)$$

P_{BOG} can be read from the relation between the calculated Daily LNG consumption and the corresponding power. Typical curves given as example in following figure.

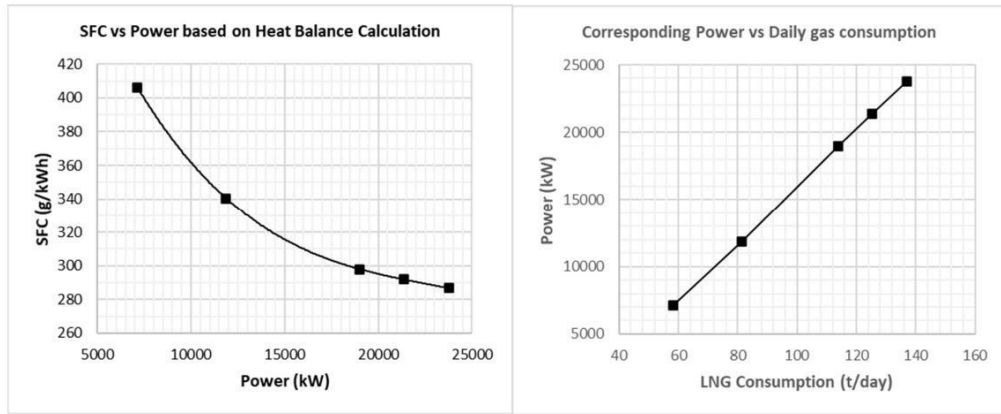

Figure 1 Example of SFC vs Power from heat balance and Corresponding Power vs Daily Gas Consumption curves for a typical steam ship

2 Calculation of diesel electric LNG carriers

This deduction is only acceptable if no reliquefaction plant is installed. In case a reliquefaction plant is installed then the additional auxiliary power to be used. The below methodology considers LNG as the primary fuel.

Considering that DFDEs are fitted with dual fuel auxiliary engines with no dedicated LNG fuel tanks, and DFDEs do not have separate MEs & AEs but have a number of 4-stroke Dual Fuel Gensets all acting as MEs, the formula for the Attained EEXI for Diesel Electric LNG carriers is simplified:

$$Attained \ EEXI = \frac{(P_{ME} + P_{AE}) \times (C_{FMEGas} \times SFC_{MEGas} + C_{FMEPilotfuel} \times SFC_{MEPilotfuel})}{Capacity \times V_{ref}}$$

In case of power limitation and after deduction of the power from combustion of excessive natural boil-off gas, the formula changes as follows (The methodology can only be applied to power limitation cases):

$$Attained \ EEXI = \frac{(P_{ME \ revised} + P_{AE}) \times (C_{FMEGas} \times SFC_{MEGas} + C_{FMEPilotfuel} \times SFC_{MEPilotfuel})}{Capacity \times V_{ref} \times (P_{ME \ lim})}$$

where:

MPP —Rated output of motor, in kW;

MPP_{lim} —limited installed power of motor, in kW. The calculation of MPP_{lim} is an iterative process, as a reduction factor R_f is to be applied until Attained EEXI is less than or equal to Required EEXI, to be calculated as follows:

$$MPP_{lim} = R_f \times MPP$$

where: R_f is reduction factor, $R_f < 1$;

$P_{ME} = 0.83 \ MPP / \eta_{electrical}$;

$\eta_{electrical}$ —electrical efficiency, to be taken as 0.913;

$P_{ME_lim} = 0.83 MPP_{lim} / \eta_{electrical}$;

P_{AE} —power of auxiliary engine, in kW;

V_{ref} —reference speed, in kn;

$Capacity$ —in t;

C_{FMEGas} —carbon conversion factor of fuel used in the 4-stroke dual fuel gensets (considered as ME in this case), on gas mode;

$C_{FMEPilotfuel}$ —carbon conversion factor of pilot fuel;

SFC_{MEGas} —Certified specific fuel consumption of the 4-stroke dual fuel gensets (considered as ME in this case), on gas mode, in g/kWh;

$SFC_{MEPilotfuel}$ —Specific fuel consumption of pilot fuel for dual fuel ME at 75% MCR according to test bed result, in g/kWh;

$P_{ME_revised}$ —the relevant power value after deduction of $P_{Excessive}$, in kW, to be calculated as follow:

$$P_{ME_revised} = 0.83 \times \frac{MPP_{lim}}{\eta_{electrical}} - P_{Excessive}$$

$P_{Excessive}$ —the excessive power from combustion of excessive natural boil-off gas, in kW, to be calculated as follow:

$$P_{Excessive} = P_{BOG} - \left(\frac{MPP_{lim}}{\eta_{electrical}} + P_{AE} \right)$$

P_{BOG} —the nominal power generated by consuming all boil-off gas from the cargo tanks, which may be determined in accordance with the daily boil-off rate (BOR_{LNG}) and inputs from the Gensets NOx Technical File (Parent Engine). The calculation formula is as follows:

$$P_{BOG} = \frac{BOR_{LNG} \times 1000000}{SFC_{MEgas} \times 24} \quad [kW]$$

where: BOR_{LNG} —Daily boil-off rate, in t/day, to be calculated as follow:

$$BOR_{LNG} = 0.000864 \times V_{Cargo}$$

where: V_{Cargo} —Cargo Tank Volume to be taken as the 100% net volume, in m³.

SFC_{MEgas} —the weighted average corresponding to the 75% of the engines' MCR values.

Typical curve of daily LNG consumption vs Power is given as example in following figure.

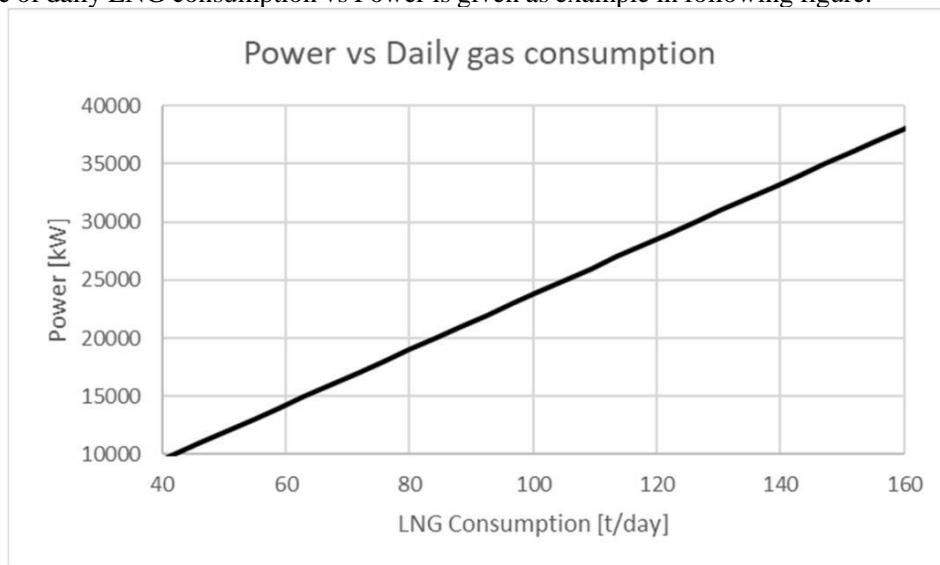

Figure 2 Example of daily LNG consumption vs Power for a typical DFDE ship

APPENDIX 3 GUIDANCE ON METHODS, PROCEDURES AND VERIFICATION OF IN-SERVICE PERFORMANCE MEASUREMENTS

1 Introduction

In cases where the speed-power curve is not available or the sea trial report does not contain the EEDI or design load draught condition, the ship speed V_{ref} can be obtained from the in-service performance measurement method for the purpose of the EEXI calculation.

2 Overview

2.1 When carrying out the in-service performance measurements, common international standards^① are to be referred to, unless explicitly specified in this appendix.

2.2 An overview of preparations and procedures are outlined in the table below. The preparations and the processes should be discussed and agreed at the pre-meeting, see section "Preparations".

Table 1: In-service performance sea trial preparations and procedures

In-service performance measurement analysis	
Step 1: Preparing sensors	<ul style="list-style-type: none"> • Speed log / GPS • Echosounder • Heading control • Fuel flow meter • Shaft torsion meter • Draft measurement • Gyro compass
Step 2: Pre-trial parameters	<ul style="list-style-type: none"> • Displacement • Forward/Aft draughts • Water depth • Air/Sea temperature • Seawater density • Anemometer height • Fuel density • Fuel LCV
Step 3: In-service performance measurement	<ul style="list-style-type: none"> • Sea state • Wind • Water depth • Currents

^① Such as ITTC quality procedures, ISO 15016:2002, ISO 15016:2015 and/or ISO 19030:2016.

Step 4: During trial parameters	<ul style="list-style-type: none"> • Reported data • System prints • Equipment control • Fuel analysis
Step 5: Documentation	<ul style="list-style-type: none"> • Shaft RPM/Power • Heading • Ship's speed • Distance • Wind speed/direction • Current speed/direction • Wave height/period/direction

2.3 When using the in-service performance measurement method, a meeting is to be arranged between all stakeholders involved in the process: the owner, the possible consultant, the verifier and the authority before conducting the in-service performance measurements. An overview of the available information including but not limited to ship design, energy saving devices (ESD) and measurement sensors are to be included. The plan for the period of the in-service performance measurements is to be agreed upon and expectations regarding the delivery of the analysis and its format are to be aligned.

3 Preparations

3.1 Relevant instruments should be calibrated and their operational conditions prior to the commencement of the trials are to be confirmed by the verifier. The list below indicates the primary instruments to be used for collecting the data:

Table 2: Sensors for In-service performance trials

Sensor	Remarks
Shaft torque meter	The measurement system is to be certified for power measurements with a bias error as small as practicable. Zero setting checked before and after test.
GPS	The GPS system is to operate in the differential mode to ensure sufficient accuracy.
Anemometer	It is to be clear of possible obstructions (superstructure, masts, funnel, etc.) and its height from sea level recorded.
Draft measurements	Draft measurement system (if available and calibrated): Otherwise, physical observation is required.
Speed log	The sensor is to have been cleaned recently.
Echo sounder	Important for checking water depth for safety and ensuring there are no effects from shallow water on the ship performance.
Course recorder	Should be checked before the trial and be able to provide a course printout following each trial run.
Fuel flow meter	Either volume flow or mass flow meters to be fitted to ships. Both are to be calibrated and cleaned/maintained as per manufacturer's recommendations.
Gyro compass	Record the ship's heading during the voyage and is to be calibrated prior to the trials.

3.2 The ship is to be equipped with a calibrated shaft torque meter, at least for the complete duration of the in-service performance measurement. For verification and cross checks, the detailed fuel properties

information, the logged engine room conditions and the fuel oil consumption details will give an estimate of the power used at a certain fuel oil consumption value.

3.3 If an automated data acquisition system is installed on board, this is to be checked for accuracy prior to the performance measurements, to ensure that the system has the required precision and measurement frequency, that can provide a trace of all the data required.

3.4 Before the start of each performance measurement run, the following are to be noted in the data logging template form (example annex C):

Table 3: In-service environment and conditions

Parameter	Remarks
Displacement	Speed trials should be performed at displacement and draught conditions, which are comparable to those of the delivery sea trials or model tests or assumed ballast conditions. The trim shall be maintained within very narrow limits. For the even keel condition, the trim shall be less than 0.1 % of the length between perpendiculars. For the trimmed trial condition, the fore draught shall be within ± 0.1 m of the ship's ideal condition.
Draught forward, mid and aft	
Water depth	No remarks
Air temperature	Air temperature and pressure should be measured using a calibrated thermometer and barometer.
Air pressure	
Sea water temperature	The local seawater temperature and density at the trial site are to be recorded to enable the calculation of the ship's displacement and corrections with regards to viscosity. The water temperature is to be taken at the waterline level.
Sea water density	
Anemometer height	Its height from sea level should be recorded.
Fuel density	The fuel's density and LCV to be obtained from a laboratory's analysis report.
Fuel LCV	

3.5 The in-service performance measurements should be performed at the EEXI draught condition, and if data exists for a reference condition, then a set of in-service performance measurements may also be performed at this condition in order to better calibrate the speed-power relation.

(1) The reference condition is the condition for which the ship documentation exists, e.g. a sea trial curve in ballast or a sea trial/model test curve in design conditions. The in-service performance measurement result may be calibrated towards the reference condition curve. The use of a reference condition, if available, should not lead to overestimation of the V_{ref} but can be a useful tool to verify and calibrate the speed-power relation. If a reference condition is used, this calibration result may also be used for the EEXI draught condition.

(2) The EEXI draught condition is the draught condition as provided by paragraph 2.3.2 of Guidelines on Calculation and Verification of Energy Efficiency Design Index (EEDI) for Sea-going Ships Engaged on International Voyages. The performance measurements results are used with the same calibration factor as at the reference condition if available.

3.6 In case the exact EEXI draught condition cannot be met, the Admiralty Coefficient formula^① may be accepted to adjust the speed-power relation, only for displacement variations of up to 2%, or to the satisfaction of the verifier.

3.7 The ship is to perform at least one set of in-service performance measurements for the EEXI draught condition, and at power settings equivalent to the EEDI trial conditions. If that is not possible, then at each of the following power settings of 30%, 60%, 75% and 90% of MCR, with a margin of +/- 5%. If data for a reference condition is available, another set of in-service performance measurements are also to be carried out at this condition for calibration purposes.

3.8 In case where an power limitation/power reduction modification is adopted, the power settings of 30%, 60%, 83% and 90% of the limited power may be used, with a margin of +/- 5% for both sets of in-service performance measurements, to the satisfaction of the verifier.

3.9 If the in-service performance measurements are performed at consecutive power settings, sufficient time in between change of settings should be considered, to be sure that steady state conditions are obtained.

3.10 The duration of each run should be performed according to table 4.

3.11 Prior to the in-service performance measurements, the weather forecast is to be studied to ensure that favourable weather conditions will prevail during the trials (close to calm conditions).

3.12 Crew members involved in the execution are to be familiar with the performance measurements and be aware of their tasks and the importance of the measurements collected.

3.13 Safety of the ship is paramount, and the performance measurements are to be suspended should any risks to the ship and/or crew be detected. All rules and regulations, as well as good seamanship, are to be followed at all times.

3.14 The conditions and plans specified in this section are to be examined and confirmed by the verifier prior to the in-service performance measurements.

3.15 The ship may experience fouling of the hull and the propeller, which may influence the performance of the ship. If the ship is heavily fouled during the in-service performance measurements, the V_{ref} attained may be less than expected and this will lead to a penalty in the attained EEXI. It is recommended to carry out in-service performance measurements when the ship has a clean hull and propeller.

3.16 The ship may have installed ESDs post delivery. This will affect the performance and the in-service measurement may be used to reflect the effect of ESDs.

4 During the in-service performance measurements

4.1 All control levers are to remain unchanged except rudder angles required to maintain heading.

4.2 An experienced helmsman or adaptive autopilot will be required to maintain heading during each run. Minimum rudder angles are to be used while maintaining a steady heading. The helm corrections are to be limited to five (5) degrees or less.

4.3 The following conditions should be met, in order to reduce the influence of corrections and obtain the best possible accuracy of the results of the performance measurements:

Table 4: Environmental conditions for in-service performance measurements

Parameter	Remarks
Sea state	Conditions as specified in ISO 15016: 2015
Wind speed	Conditions as specified in ISO 15016: 2015
Water depth	Conditions as specified in ISO 15016: 2015
Currents	Avoid areas with known high current values and variations. During the trials, the following condition should be met: $V_{GPS} - V_{STW} < 0.3$ knots, or conditions as specified in ISO 15016: 2015
Trials period	Trials are to be conducted in daylight
Duration	The run duration should be the same for all speed runs with a minimum of 10 minutes, see figure 1 below

① Refer to specifications in 3.3.1 of PART THREE of Practical Manual of Ship Design, Volume of General.

4.4 If any of above conditions are no longer met during in-service performance measurements, it is to be necessary to abandon the run.

4.5 Each set of the in-service performance measurements in the respective load condition is to be executed as at least one set of double runs. It is important that the ship is running on the same track and when the monitoring begins, the conditions are in steady state conditions. Each speed run is to be commenced and completed at the same place.

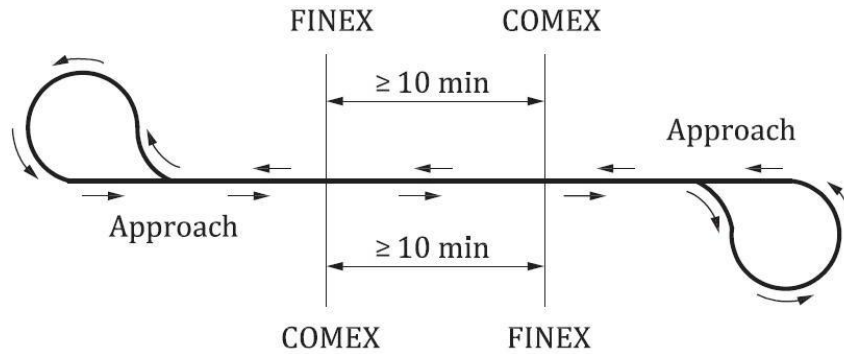

Figure 1: Sea trials with double runs

4.6 During the in-service performance measurements, accurate recording of parameters for each run is to start when steady state ship conditions are met.

4.7 The following data is to be collected at the beginning and end of each performance measurement run:

Main engine supply flowmeter reading	[ltr/h) or [kg/h)
Main engine supply flowmeter temperature	[deg)
Main engine return line flowmeter reading*	[ltr/h) or [kg/h)
Main engine return line flowmeter temperature*	[deg)

(*For ships fitted with flowmeter on return line)

4.8 The following data is to be collected with a sampling rate of at least 1 Hz during the in-service performance measurement:

Table 5: Logged parameters during in-service performance measurements

Parameter	Unit
Date	dd-mm-yyyy
Time	hh:mm:ss
Revolution counter reading	[s ⁻¹)
Shaft power	[kW)
Heading	[deg)
Ship's speed (GPS and Speed Log)	[kn)
Distance ("0" should be at the beginning of each run)	[nm)
Relative wind speed	[m/s)
Relative wind direction (coming from)	[deg)

Current speed	[kn]
Relative current direction (going to)	[deg]
Observed wave height	[m]
Observed wave period	[s]
Observed wave direction (going to)	[deg]

4.9 Apart from power, rpm and consumption, average prevailing values for the following main engine parameters are to be provided for each run for the following:

Scavenge air temperature	[deg]
Scavenge air pressure	[kg/cm ²]
Blower air inlet temperature	[deg]

4.10 These, as well as any other main engine data are to be collected at local sensors' display and not their repeaters inside the ECR.

4.11 As far as practicable, the in-service performance measurement is to be witnessed by the verifier. The verifier is to be able to confirm that the in-service performance measurement was conducted in accordance with the agreed procedures.

5 After the in-service performance measurements

5.1 All information collected are to be checked by the verifier and any errors/typos are to be noted in supplementary documentation, including any corrected/replaced values clearly marked in the form. Data which is continually recorded should be provided "as is" and non-variable data is to be noted at the beginning and the end of the in-service performance measurements in order to confirm that any changes are set to a minimum.

5.2 For each run the following are to be submitted:

- .1 one filled-in soft copy of the "In-service performance monitoring reporting form" (annex C);
- .2 printouts and/or soft copies from the performance monitoring system output;
- .3 printouts and/or soft copies from the loading computer calculations representing the loading condition at which the run took place; and
- .4 printouts and/or soft copies from the course recorder for the period covering the run.

5.3 Also, a copy of the fuel oil analysis for the fuel used during the in-service performance measurements should be submitted.

5.4 Any comments about the in-service performance measurements, including any large variations in environmental conditions, are to be noted.

5.5 A summary of the required information to be submitted for verification can be found in annex A, B, and C.

ANNEX A
INFORMATION TO BE SUBMITTED PRIOR TO CONDUCTING THE IN-SERVICE
PERFORMANCE MEASUREMENTS

The following information are to be submitted prior to conducting the performance measurements.

Document	Mandatory	Optional
Hydrostatics	<input type="checkbox"/>	<input checked="" type="checkbox"/>
Shop tests of main engine	<input checked="" type="checkbox"/>	<input type="checkbox"/>
Sea trials (machinery and hull part)	<input checked="" type="checkbox"/>	<input type="checkbox"/>
Model tests	<input type="checkbox"/>	<input checked="" type="checkbox"/>
Propeller characteristics and structural drawings	<input type="checkbox"/>	<input checked="" type="checkbox"/>
GA drawing	<input checked="" type="checkbox"/>	<input type="checkbox"/>
Details of appendages and rudder	<input type="checkbox"/>	<input checked="" type="checkbox"/>
Fuel oil piping diagram	<input type="checkbox"/>	<input checked="" type="checkbox"/>

Ship's main particulars

IMO number:	
Date delivered:	
Ship's email address(s):	
Date ship was launched (when did ship enter the water):	
Ship's name:	
Owner:	
Managing company:	
Ship type:	
Ship capacity (DWT or GT)	
Yard:	
Length overall (m):	
Length between perpendiculars (m):	
Breadth moulded (m):	
Depth to upper deck (m):	
Design draft (m):	
Design displacement (mt):	
EEXI draft (m):	
Displacement at EEXI draft (mt)	
Lightship weight (mt)	
Design speed (knots):	

Dry-docking history (within the last five years):			
Date	Yard	Coating specs	Hull treatment
		Please attach	Please attach

Hull cleaning and propeller polishing history since last dry-dock:			
Date	Place	Brief description of works	Propeller polishing standard*

*only for propeller polishing events

Main engine(s)	
Maker:	
Type:	
Number:	
Type of fuel:	
MCR (kW)	
SMCR (kW) x RPM	

Main engine modifications/upgrades	Yes	No
Derating	<input type="checkbox"/>	<input type="checkbox"/>
T/C cut offs	<input type="checkbox"/>	<input type="checkbox"/>
Part load tuning	<input type="checkbox"/>	<input type="checkbox"/>
Low load tuning	<input type="checkbox"/>	<input type="checkbox"/>
Retrofit	<input type="checkbox"/>	<input type="checkbox"/>
(please provide details)		
Other modifications	<input type="checkbox"/>	<input type="checkbox"/>
(please provide details)		

Propeller(s) including modifications/upgrades		
Type: (FP or CPP)		
Diameter (m)		
Pitch (m)		
Number		
	Yes	No
Trimmed	<input type="checkbox"/>	<input type="checkbox"/>
Other (please state)	<input type="checkbox"/>	<input type="checkbox"/>

Propulsion improvement devices	Yes	No
Ducts	<input type="checkbox"/>	<input type="checkbox"/>
Fins	<input type="checkbox"/>	<input type="checkbox"/>
Other (please provide details)	<input type="checkbox"/>	<input type="checkbox"/>

Power measurements	Yes	No
By torsion meter	<input type="checkbox"/>	<input type="checkbox"/>
(Details of torsion meter including last calibration)		
By load indicator diagrams	<input type="checkbox"/>	<input type="checkbox"/>
Other method (please provide details)		

Performance monitoring systems	Yes	No
PMS	<input type="checkbox"/>	<input type="checkbox"/>
please provide details of type and maker		

Fuel measurements	Yes	No
By volume flowmeter	<input type="checkbox"/>	<input type="checkbox"/>
(Details of flowmeter including last calibration)		
By mass flowmeter	<input type="checkbox"/>	<input type="checkbox"/>
(Details of flowmeter including last calibration)		
Soundings	<input type="checkbox"/>	<input type="checkbox"/>

Other instruments & gauges used for data collection	Dates of Calibration
Speed log	
DGPS	

Anemometer Provide height of anemometer in metres:	
Other (please provide details)	

Additional information	Yes	No
Reduction gear	<input type="checkbox"/>	<input type="checkbox"/>
(please provide details)		
Shaft motor	<input type="checkbox"/>	<input type="checkbox"/>
(please provide details)		
Shaft generator	<input type="checkbox"/>	<input type="checkbox"/>
(please provide details)		

Person to be contacted for further info:	
--	--

ANNEX B
INFORMATION TO BE SUBMITTED FOR VERIFICATION AFTER THE IN-SERVICE
PERFORMANCE MEASUREMENTS

The following information needs to be submitted after conducting the in-service performance measurements.

Document	Mandatory	Optional
Calibration certificate of torquemeter	<input checked="" type="checkbox"/>	<input type="checkbox"/>
Calibration certificate of flowmeters	<input type="checkbox"/>	<input checked="" type="checkbox"/>
Calibration certificate of anemometer	<input type="checkbox"/>	<input checked="" type="checkbox"/>
Calibration certificate of speed log	<input type="checkbox"/>	<input checked="" type="checkbox"/>
Calibration certificate of GPS	<input type="checkbox"/>	<input checked="" type="checkbox"/>
Calibration certificate of echosounder	<input type="checkbox"/>	<input checked="" type="checkbox"/>
Calibration certificate of gyro compass	<input type="checkbox"/>	<input checked="" type="checkbox"/>
Fuel oil analysis	<input checked="" type="checkbox"/>	<input type="checkbox"/>

Furthermore, for each run, the following needs to be submitted:

Document	Mandatory	Optional
Sea trial reporting form	<input checked="" type="checkbox"/>	<input type="checkbox"/>
A printout of course recorder	<input checked="" type="checkbox"/>	<input type="checkbox"/>
A printout of ME load indicator (depicting the loading condition of the ship during the trials)	<input type="checkbox"/>	<input checked="" type="checkbox"/> *
A printout/soft copy of the anemometer output (if the anemometer is digital)	<input type="checkbox"/>	<input checked="" type="checkbox"/> *

* Optional, but highly recommended outputs

ANNEX C

EXAMPLE OF THE IN-SERVICE PERFORMANCE MEASUREMENTS REPORTING FORM

In-service Performance Monitoring reporting form

Vessel name _____ IMO # _____

Air temperature [°C]		SW temp [°C]		SW density [ton/m ³]														
Draught fore [m]		Draught aft [m]		Displacement [ton]														
Fuel density [kg/m ³]		Fuel LCV [kJ/kg]		Anemometer height [m]		Water depth [m]												
Engine Room								Bridge										
Observation #	Run #	Obs. Start	Elapsed time	ME Supply Flowmeter Reading	ME Supply Flowmeter Temperature	ME Return Flowmeter Reading	ME Return Flowmeter Temperature	Revolution Counter Reading	Shaft Power	Heading	Speed	Distance	Relative Wind Speed	Relative Wind Direction	Current Speed	Observed Wave height	Observed Wave Period	Observed Wave Direction
		hh:mm	mm	ltr(1)	°C	ltr(1)	°C	rounds	kW	°True	knots	nm	knots	°Relative	going to knots	m	sec	°True

1	1		10																
	2		10																
2	1		10																
	2		10																
3	1		10																
	2		10																
4	1		10																
	2		10																

Average Value for power setting #1	Scavenging Air Temperature	°C	Scavenging Air Pressure	kg/cm ²	Blower Air Inlet temperature	°C
Average Value for power setting #2	Scavenging Air Temperature	°C	Scavenging Air Pressure	kg/cm ²	Blower Air Inlet temperature	°C
Average Value for power setting #3	Scavenging Air Temperature	°C	Scavenging Air Pressure	kg/cm ²	Blower Air Inlet temperature	°C
Average Value for power setting #4	Scavenging Air Temperature	°C	Scavenging Air Pressure	kg/cm ²	Blower Air Inlet temperature	°C

APPENDIX 4 VERIFICATION OF NUMERICAL CALCULATIONS

1 To ensure the accuracy and rationality of the calculation results, the additional information to be submitted for the ships obtaining V_{ref} by numerical calculation are at least to include but not limited to the following contents:

(1) Description of objectives: The numerical calculation work is introduced and the objectives of the simulation are explained, the existing results of the method used are compared with the results of the model test/real ship trial, and the applicable calibration factors. Relevant supporting examples are listed in the annex to the report

(2) Qualification for numerical calculation: The party submitting the numerical calculation report is required to provide a description of its numerical calculation capability in accordance with ITTC 7.5-03-01-02;

(3) Supporting document: the document basis for numerical calculation by the party submitting the numerical calculation report, such as model test report, sea trial report, lines, general arrangement plan, propeller plan, etc.;

(4) Description of ship and propeller: Ship information includes ship name, ship type, design draft, EEDI draft, lightweight and deadweight, rated power of main engine, LPP, moulded breadth, moulded depth, etc. Propeller information includes diameter, number of blades, direction of rotation, expanded area ratio, hub diameter, chord Length at $0.7R$, Max. thickness at $0.7R$, pitch ratio at $0.7R$, type of energy-saving device (ESD), if applicable;

(5) Description of CFD software: A brief introduction to the types and versions of software used;

(6) Description of CFD modelling, including:

- ① Detailed description of the geometric model (including appendages such as rudder) to determine the consistency of the numerical calculation model with the real ship. Ship comparison information is at least to include scale ratio, length overall, LPP, moulded breadth, moulded depth, different drafts and their corresponding displacement volume and wet surface area (including rudder and bare hull), LCB, VCB, and comparison between lines and numerical modeling. Propeller comparison information is at least to include diameter, number of blades, direction of rotation, expanded area ratio, hub diameter, chord Length at $0.7R$, Max. thickness at $0.7R$, pitch ratio at $0.7R$, and comparison between lines and numerical modeling;
- ② The meshing strategy is to be detailed, including description of grid domain, grid size, type of grids being utilized (boundary layer, cell sizes, etc.) . These are to be provided for the different refinement zones of the domain and at every direction (x,y,z), if they differ.
- ③ Meshing views, including boundary layer grids for different parts of the hull, and close-up views of the grids at key positions of the hull (bow, stern, transom and appendage, etc.)
- ④ Research on mesh convergence to justify the selected mesh refinement. The convergence verification is to include at least three discrete meshing schemes of different sizes. Approved by the verifier, the mesh convergence research can be replaced by the results of set of comparable ships / similar ship.

(7) numerical model set-up description, including CFD equations being solved, simulation type (steady vs unsteady), turbulence model being used and justification for its choice, numerical solution schemes used, iteration stop criteria, main dimension of calculation domain, boundary condition, damp area set-up (if

any), description of the coordinates system and model origin, degrees of freedom used in the model, description on the propeller modelling, convergence criteria, description of the initial conditions used;

(8) results and post-processing, the report is to contain an explanation on the post-processing procedure (if averaged, last value, etc.) used. Also, the description of the methodology by which the final self-propulsion point was found (if propeller open water CFD simulations were used, in which case the details of these are also required). In addition, the following views and results should be provided:

- ① One figure showing an example of one of the simulations showing the residuals. Minimum of one plot per type of simulations performed: resistance, self-propulsion, open water curves, etc.
- ② A color diagram of the following results:
 - Global view of the wave pattern with wave height
 - Zoom view of the wave pattern at the bow and stern regions
 - Views of the y^+ values for the hull and appendages
 - Views of the pressure coefficient for the hull and appendages
 - Views of pressure and flow field in way of propeller
- ③ Summary of values obtained from simulations:
 - Ship resistance (total, viscous and pressure resistances)
 - Thrust deduction factor (t)
 - Wake deduction factor (w)
 - Propeller Thrust
 - Propeller Torque
 - Propeller efficiency
 - Rotation Rate
 - Delivered Power

(9) Validation assessment of numerical calculation method: A detailed description of the numerical method used to demonstrate the rationality of the numerical results.

2 The numerical calculation is to comply with relevant requirements of the latest edition of ITTC 7.5-03-01-02, ITTC 7.5-03-01-04, ITTC 7.5-03-03-01.

3 The accuracy of the numerical method used in the numerical calculation is to be verified by comparing the numerical calculation results of the parent ship, set of comparable ships or similar ship of the target ship with the results of the model test or the sea trial of the real ship. Sea trial results for comparison are to be obtained in accordance with ISO 15016:2015 or equivalent. The accuracy of the numerical calculation method is expressed by the calibration factor, which is the ratio of the numerical calculation results of the parent ship, the set of comparable ships or the similar ship to the model test or the sea trial results of the real ship under the same condition point, and the value is to be between 0.95 and 1.05 (inclusive). For the speed-power curve, the calibration factor can be verified by the average of the ratio of at least 4 power points (distributed as far as possible, including 75%*MCR* condition point) between 65%*MCR* and 100%*MCR* (inclusive). "*MCR*" is to be understood as "*MCR_{lim}*" for ships adopting power limitation/power reduction.

4 The numerical calculation results are to be calculated based on the model scale and extrapolated to the real ship scale according to the ITTC procedure. The length between perpendiculars of the ship model used for numerical calculation is not less than 6 m, and the diameter of the corresponding propeller model is not less than 200 mm.

5 The method used in the numerical calculation report and the conversion method extrapolated to the real ship scale are to be consistent with the method used to verify the accuracy of the existing method provided

in the report. The calculated results are corrected by calibration factor. If the calibration factor of each power point is inconsistent, each power point is to be corrected by its own calibration factor.

6 Specific requirements for numerical modelling are given in Table 1.

Requirements for numerical modelling

Table 1

Category	Requirement
Geometry	The calculation model is to be consistent with the designed ship.
Degrees of freedom	It is recommended to consider at least the heave and pitch degree of freedom motion effect.
Propeller modelling	Open water calculation must be fully modeled. Self-propulsion calculation is allowed to be replaced by actuator disk.
Turbulence model	Industry is commonly using <i>k-w SST</i> or <i>RSM</i> as standard model for marine applications.
Post-processing	It needs to be demonstrated that enough time steps are accounted for in the averaging of final results so to smooth potential oscillations in the results.
Roughness	Roughness is not to be taken into account directly in the numerical simulations, but in post-processing of the results following the ITTC procedure.
Turbulence intensity	It should not exceed 10%.
Y+ value	ITTC 7.5-03-02-03 to be followed

7 In order to obtain a complete speed power curve, the numerical calculation condition points on the same curve is not to be less than the number of points obtained from the model test.

8 Template Report of Numerical Calculation is given in the annex.

Annex Template Report of Numerical Calculation

1 Introduction

This report contains the numerical calculation result of EEDI reference speed (Vref) for XXX (vessel name). The procedure used in this report follows the most updated ITTC guidelines on the topic of Numerical Modelling.

The numerical modeling and solving methods used in this report have been applied to the parent ship YYY of XXX (vessel name). By comparing the numerical calculation results of the parent ship YYY (ship name) with the model test results, the calibration factor of this method is 1.02. The lines and parameter comparison between XXX (vessel name) and YYY (vessel name), the numerical calculation report of YYY (vessel name), and the comparison and analysis results of YYY (vessel name) numerical calculation results and model test results are shown in the attachment.

2 Qualification

In accordance with ITTC 7.5-03-01-02, ZZZ (COMPANY NAME) has been involved in multiple R&D on numerical calculation covering the topics of ship resistance and propulsive performance for the past 5 years.

Examples of projects are listed below:

No.	Year	Description	Ship type	Main size of ship	difference with respect to target*(%)
1					
2					
3					
4					
5					
...					
...					

*For the comparison of curve results, the average of difference of comparison results of multiple points on the curve is taken.

3 Supporting documentation

The following list of supporting documentation is used in connection to these calculations and are provided in the Annex of this report.

No.	Document name	Description
1	YYY model test report	
2	XXX general arrangement plan	
3	XXX propeller plan	
...		

4 CFD software description

The numerical calculation was performed by Cadence Fidelity Marine V10. Fidelity Marine includes a full

hexahedral unstructured mesh fabrication pre-processing, an incompressible fluid viscosity solver and a powerful post-processing module. It is Cadence's professional hydrodynamics simulation tool specifically designed for ships and offshore engineering, with the most advanced marine applications technology. It can simulate the single-phase and multiphase viscous flow around any complex ship and offshore structure, simulate the performance of deep-sea ships and shallow water ships in inland rivers, simulate the action of mooring system, and the encounter of two ships and other complex problems. It has specialized functions and modular high-precision prediction of resistance, wave resistance, maneuvering and propeller, and multi-physical field simulation functions of propeller coupling, self-propulsion prediction, cavitation and fluid-solid interaction in complex flow field.

5 Information on vessel and propeller

Vessel characteristics:

Vessel Name	
IMO number	
Vessel type	
MCR/RMP/rpm	
DWT/t	
LWT/t	
Design draft/m	
EEDI draft/m	
LPP/m	
Beam molded/m	
Depth/m	

Propeller characteristics:

Diameter/m	
Number of blades	
Rotation Direction	
Expanded Area Ratio	
Hub diameter/m	
Chord Length at 0.7R/m	
Max. Thickness at 0.7R/m	
Pitch Ratio at 0.7R	

6 CFD modelling description

6.1 Model geometry

Ship modelling information:

Item	Calculation modelling
Scale ratio	
Length overall/m	
LPP/m	
Beam molded/m	
Depth/m	
Design draft/m	

Displacement volume corresponding to design draft/m ³	
Wet surface area corresponding to design draft/m ²	
EEDI draft/m	
Displacement volume corresponding to EEDI draft/m ³	
Wet surface area corresponding to EEDI draft/m ²	
LCB/m	
VCB/m	
VCG/m	

Propeller modelling information:

Item	Calculation modelling
Scale ratio	
Diameter/m	
Number of blades	
Rotation Direction	
Expanded Area Ratio	
Hub diameter/m	
Chord Length at 0.7R/m	
Max. Thickness at 0.7R/m	
Pitch Ratio at 0.7R	

The overall geometric model of numerical modeling is shown in Figure 6.1-1.

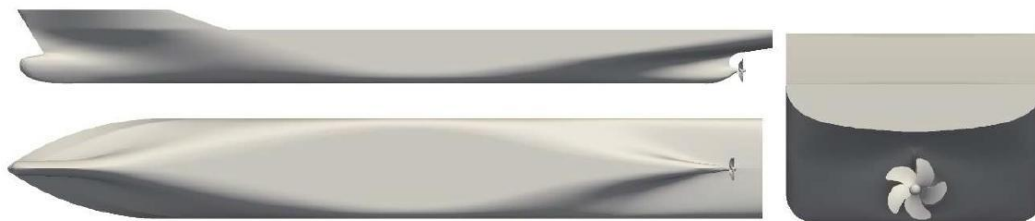

Figure 6.1-1 Overall geometric model of ship

Appendages of this model include XXX, XXX, XX and XXX.

Detailed geometric modeling of ship appendages and propulsors are shown in Figures 6.1-2 and 6.1-3.

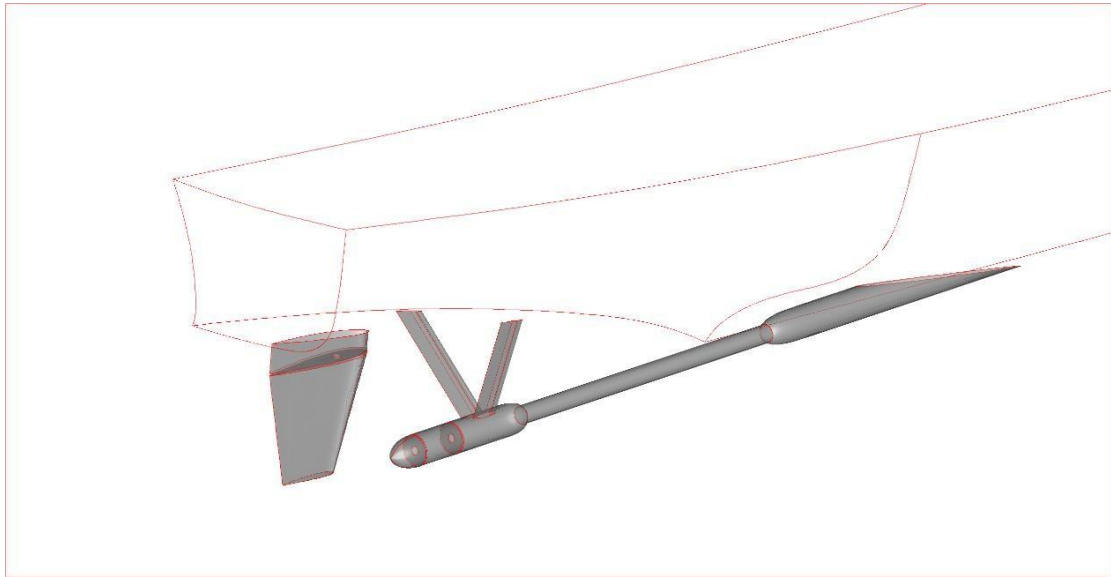

Figure 6.1-2 Geometric modeling of ship appendages

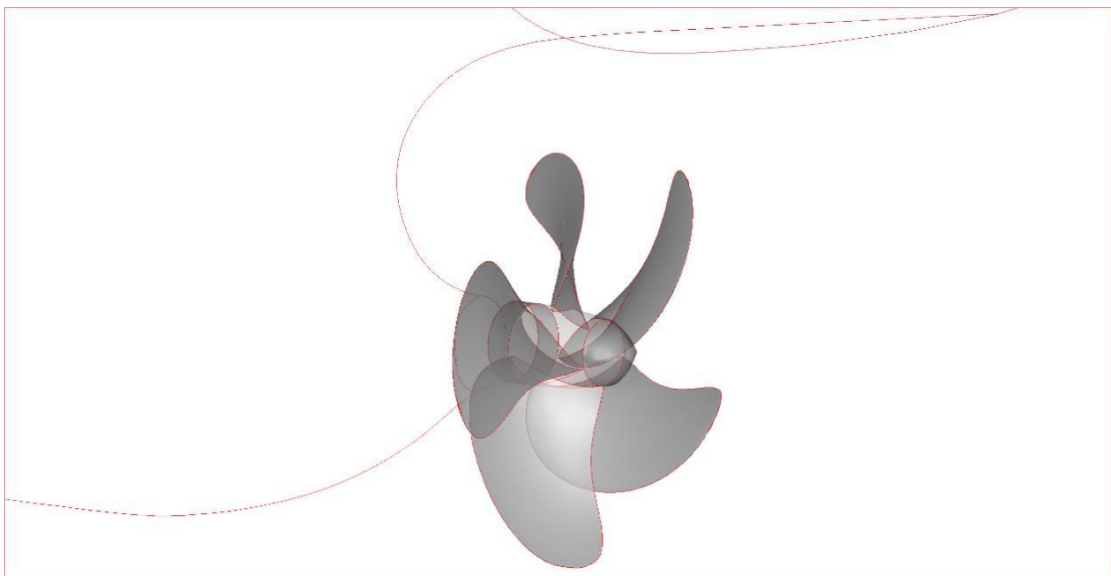

Figure 6.1-3 Geometric modeling of propulsion unit

6.2 Meshing description

(The meshing strategy is to be detailed, including description of grid domain, grid size, type of grids being utilized (boundary layer, cell sizes, etc.). These are to be provided for the different refinement zones of the domain and at every direction (x,y,z), if they differ. Different views of the different refinement zones are also to be provided and examples follow.)

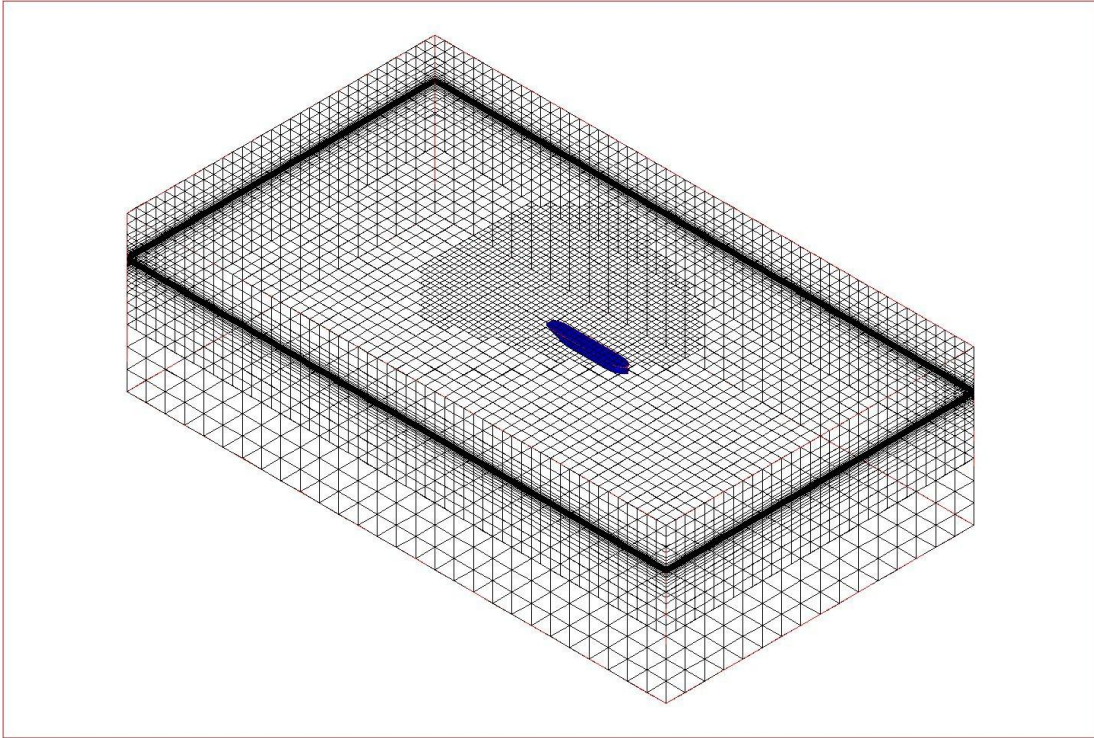

Figure 6.2-1 Division of calculation domain

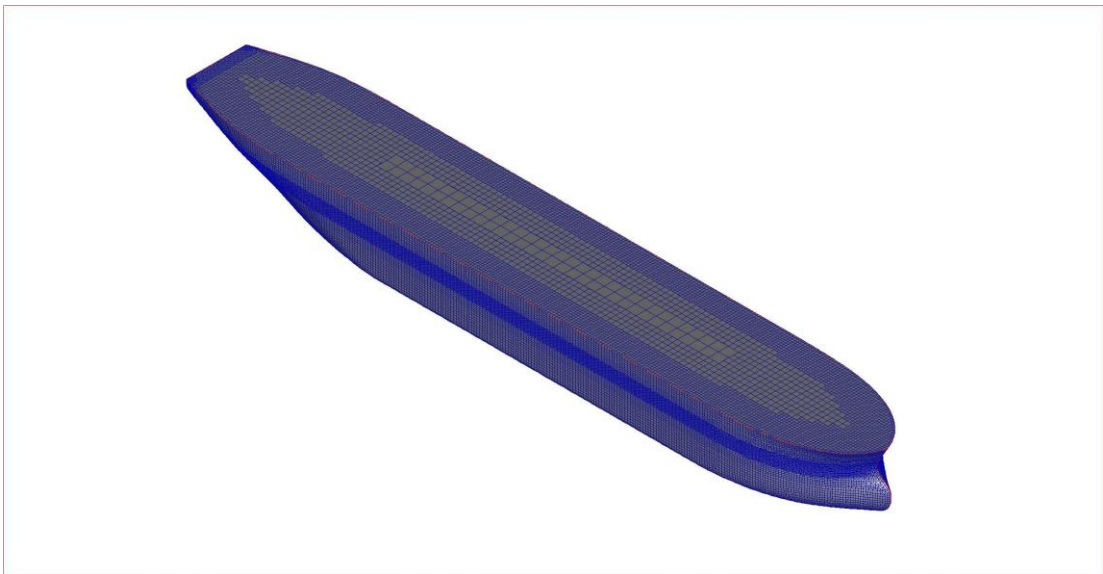

Figure 6.2-2 Meshing view

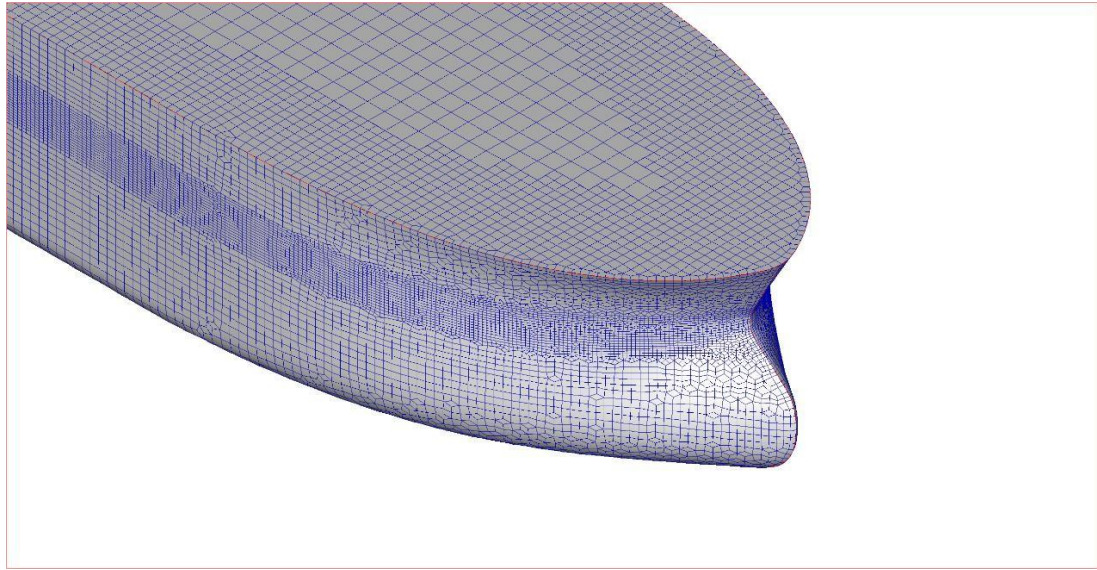
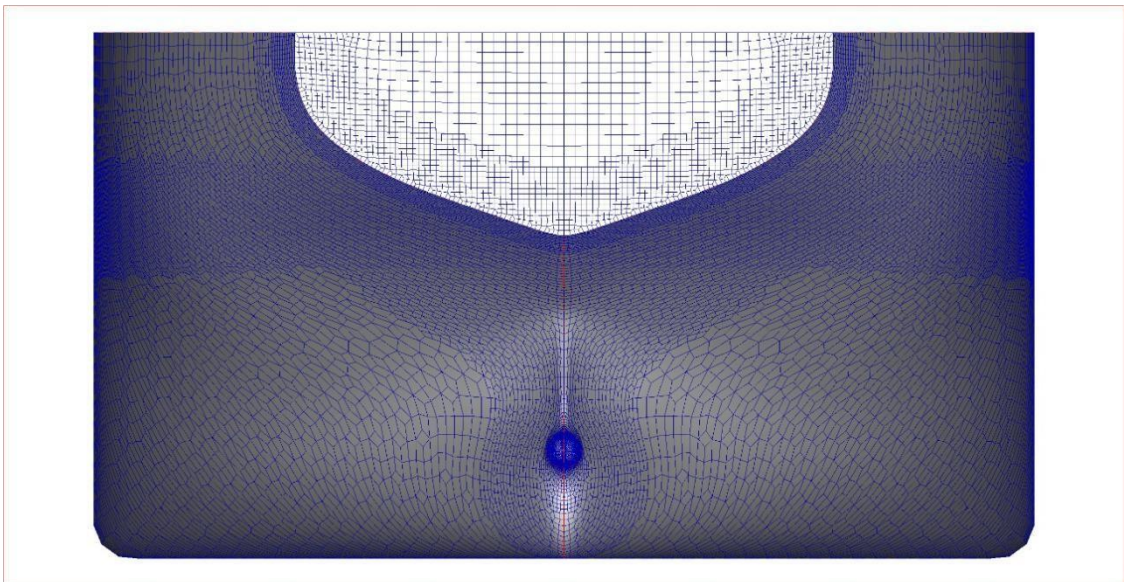
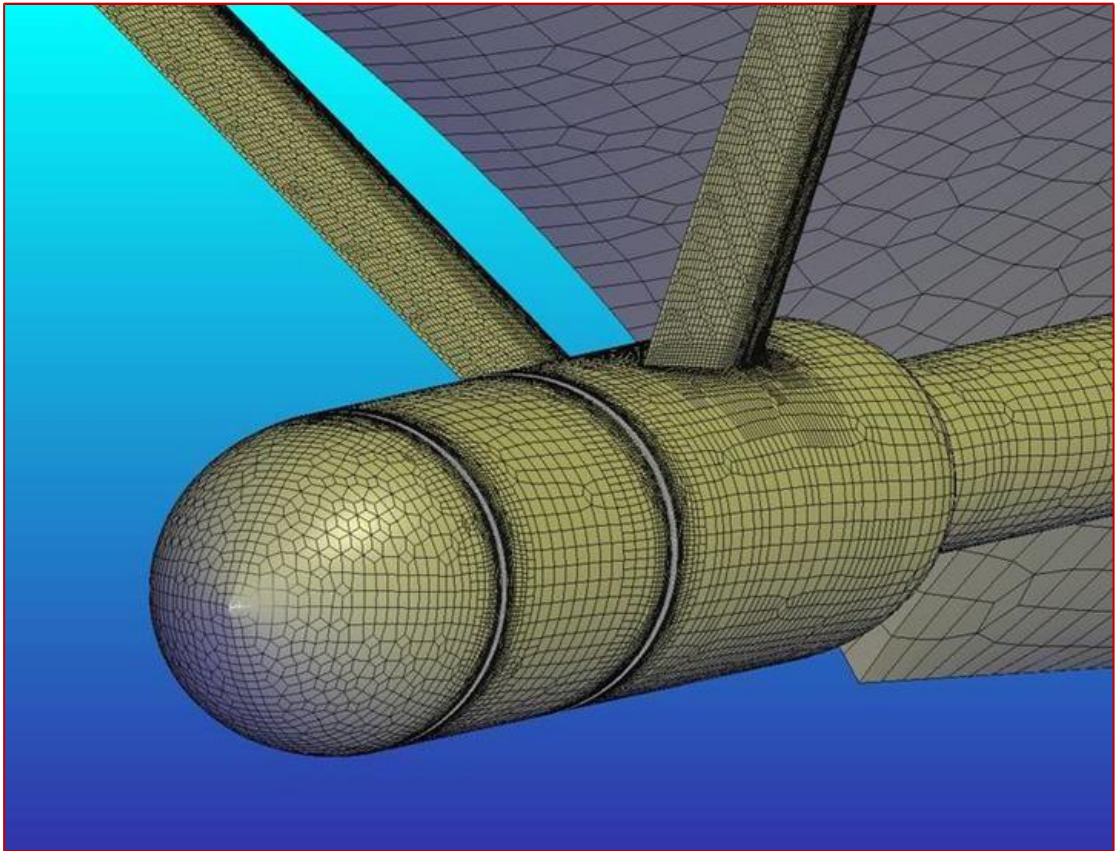
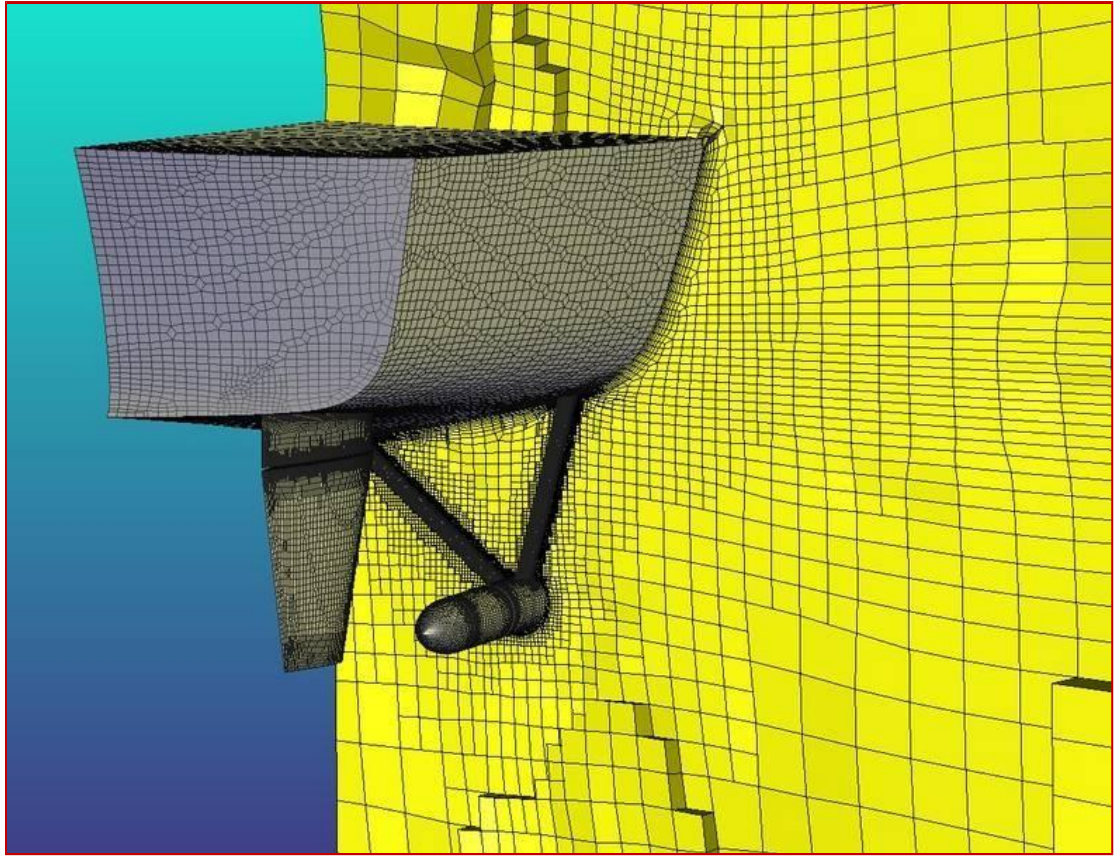

Figure 6.2-3 Meshing at bow



图

Figure 6.2-4 Meshing at stern



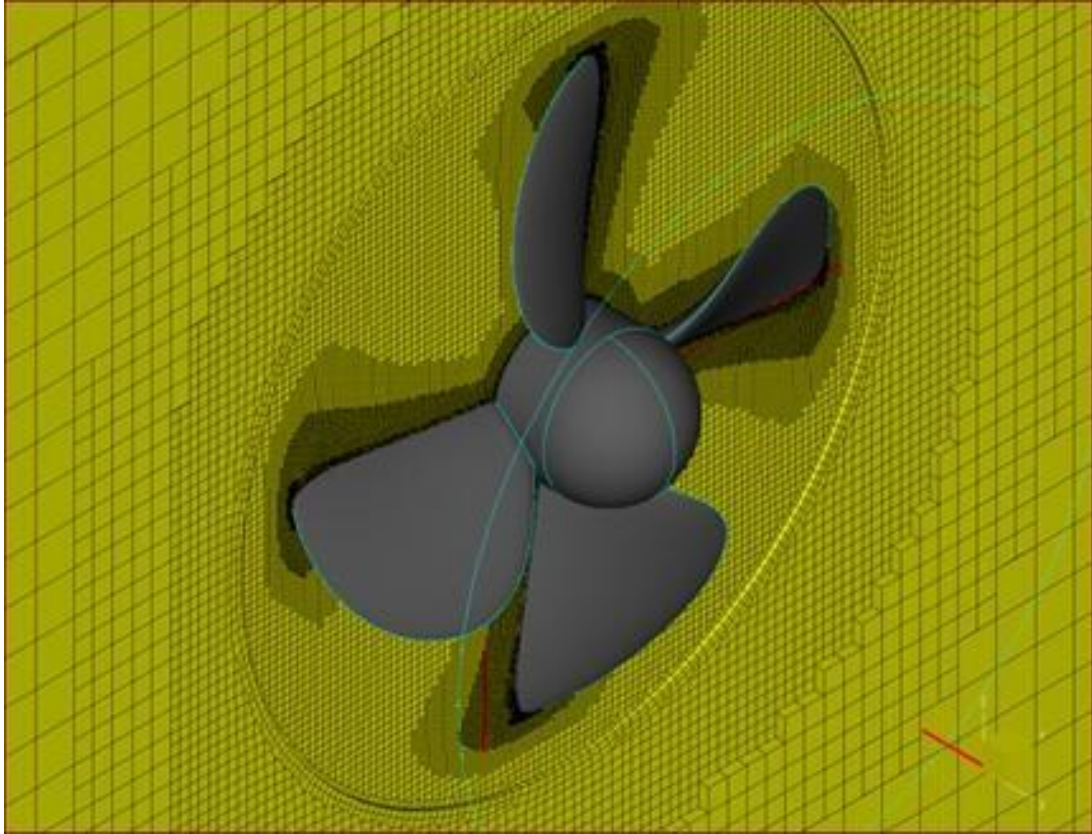

Figure 6.2-5 Meshing in way of appendage

6.3 Verification of grid convergence

The meshing of this model is the same as parent ship. Verification of grid convergence of parent ship is given in the attachment.

7 Numerical calculation set-up

7.1 CFD equations being solved

7.2 Simulation type

7.3 Turbulence model (including justification for its choice)

7.4 Numerical solution schemes (including iteration stop criteria)

7.5 Boundary conditions (including division of calculation domain)

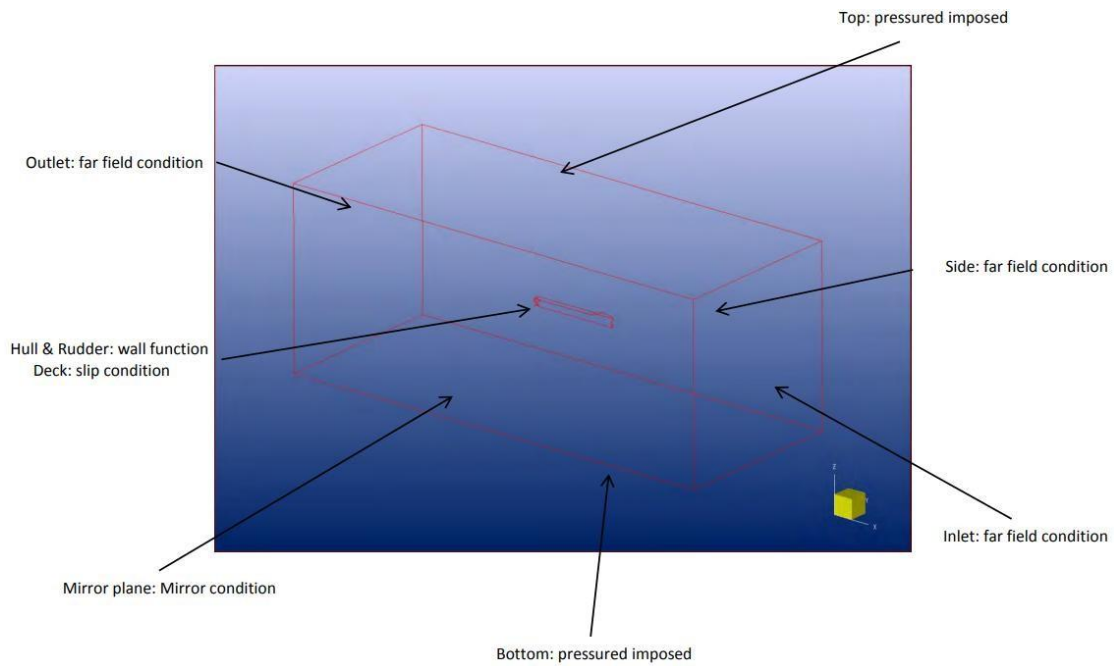

Figure 7.5 Calculation boundary condition set-up

7.6 Model coordinate system and degrees of freedom set-up

7.7 Description on the propeller modelling

7.8 Description of the initial conditions used (including convergence criteria)

8 Post-processing and result analysis

8.1 Post-processing

(A description of the post-processing procedures used (such as averages, final values etc.) and a description of the method used to find the result of the self-propulsion point)

8.2 Calculation results

8.2.1 Statistics of calculation results

Numerical calculation results of parameters at the model scale are given in the table below.

Parameter	Condition 1	Condition 2	Condition 3	Condition 10
Total resistance/N					
Viscous resistance/N					
Pressure resistance/N					
Thrust deduction (t)					
Wake deduction (w)					
Propeller Thrust/N					
Propeller Torque/N*m					
Propeller efficiency					
Rotation Rate/r/s					
Delivered Power/W					

8.2.2 Convergence Plot of Numerical Residuals

(Convergence plot of numerical residuals of static resistance, self-propelled resistance, propeller thrust and propeller torque)

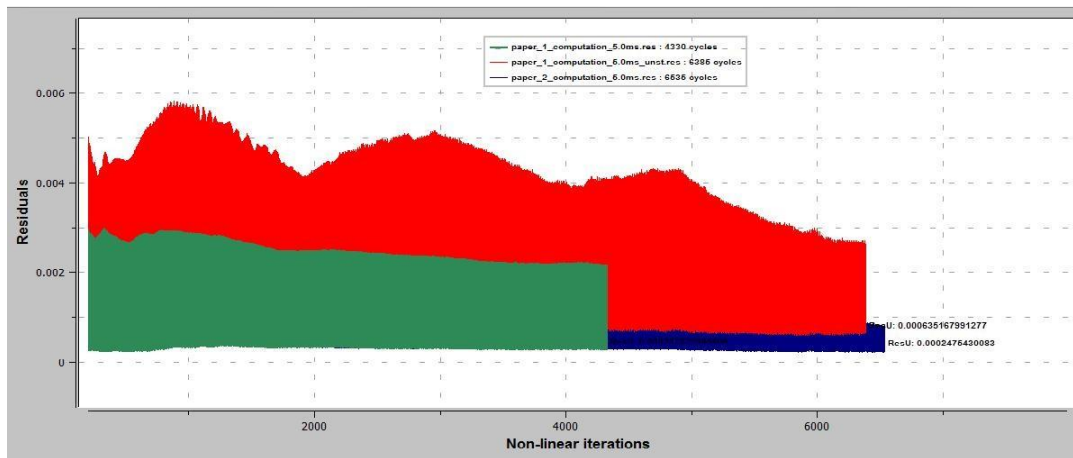

Figure 8.2.2 Convergence Plot of Numerical Residuals (example of resistance)

8.2.3 Convergence Plot of main efforts

(Convergence plot of main efforts of static resistance, self-propelled resistance, propeller thrust and propeller torque)

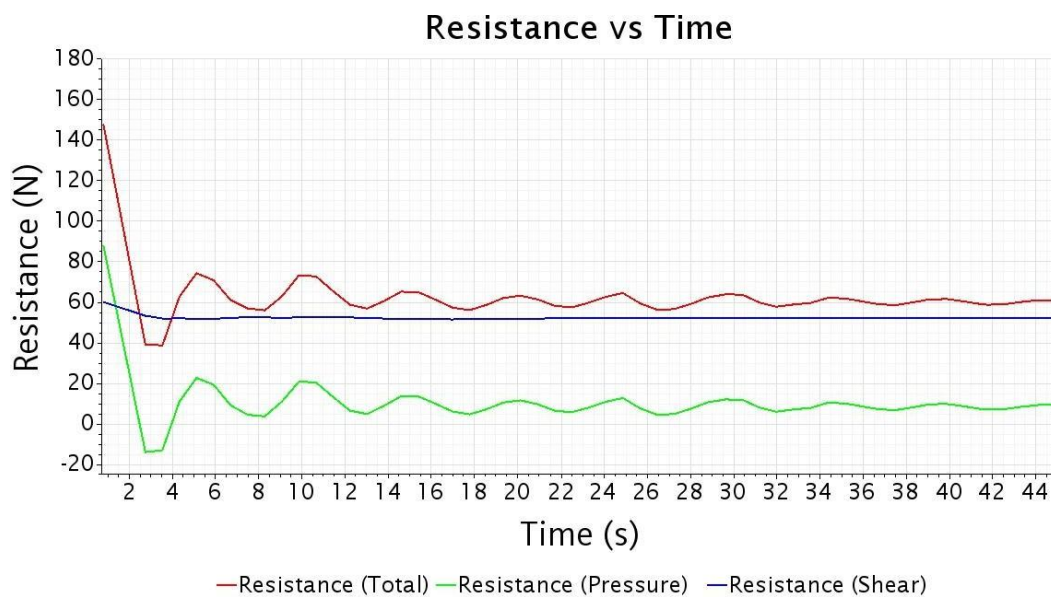

Figure 8.2.3 Convergence Plot of Main Efforts (example of resistance)

8.2.4 Wave height, pressure, flow field diagram

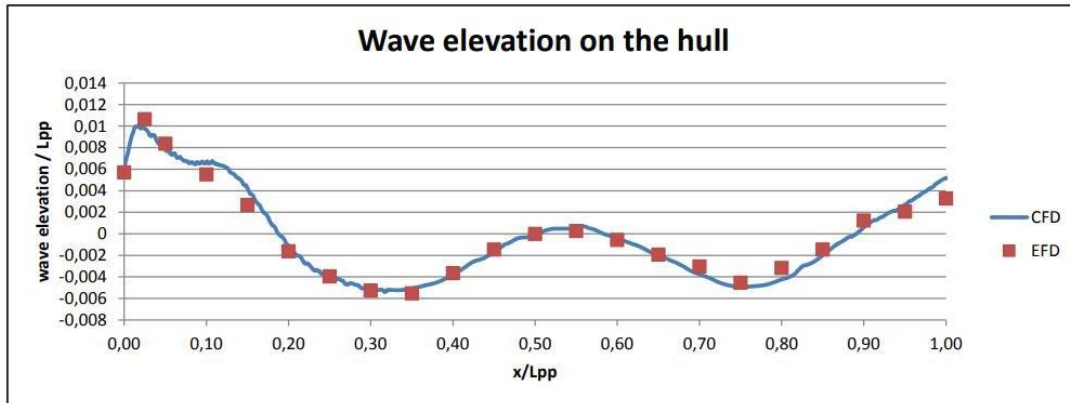

Figure 8.2.4-1 Free surface wave diagram

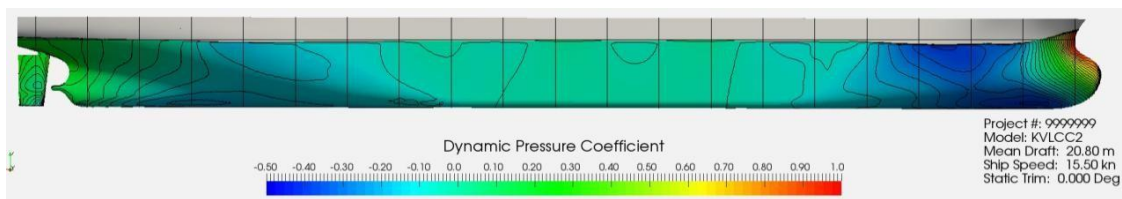

Figure 8.2.4-2 Hull pressure distribution diagram

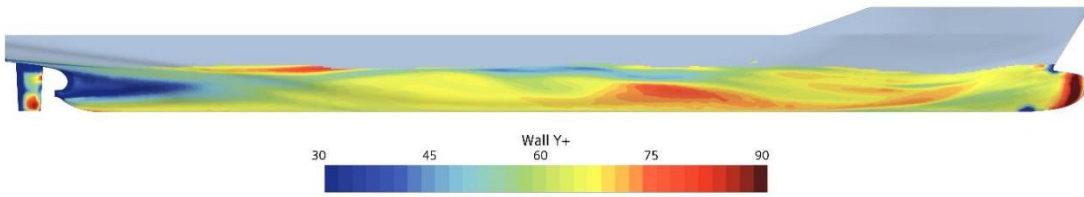

Figure 8.2.4-3 Y+ value distribution diagram

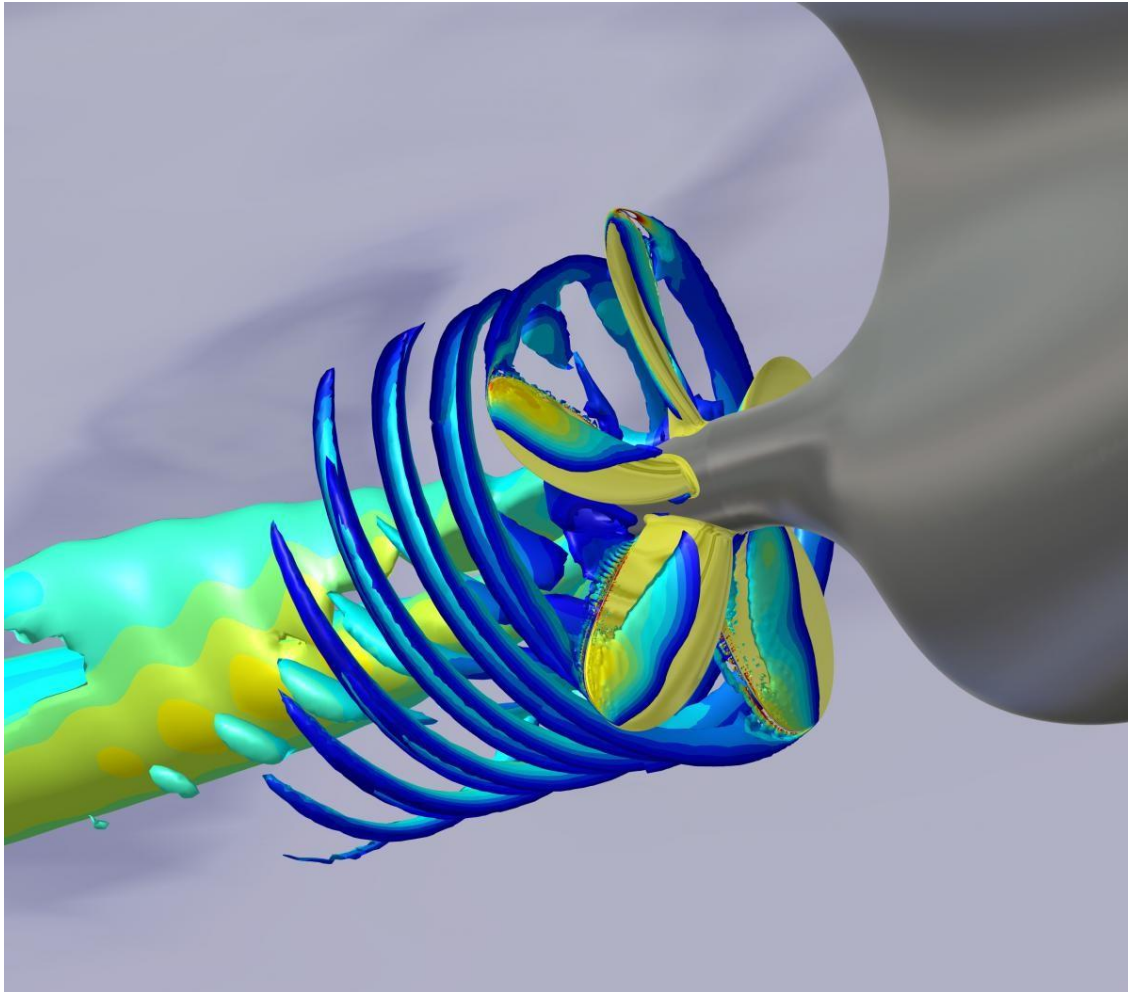

Figure 8.2.4-4 Distribution of flow field in way of propeller

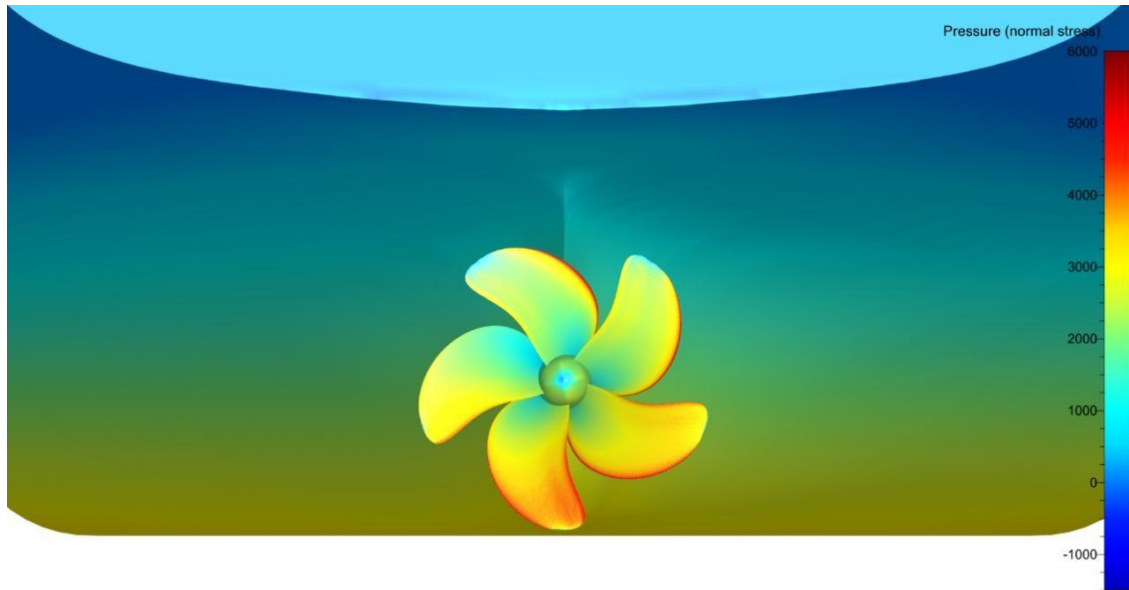

Figure 8.2.4-5 Propeller pressure distribution diagram

8.3 Result conversion

8.3.1 Model-real ship conversion method

(Description of conversion from model scale to real ship scale)

8.3.2 Result summary

The calculation results of each parameter at the real ship scale are given in the table below.

Parameter	Condition 1	Condition 2	Condition 3	Condition 10
Total resistance/kN					
Viscous resistance/kN					
Pressure resistance/kN					
Thrust deduction (t)					
Wake deduction (w)					
Propeller Thrust/kN					
Propeller Torque/kN*m					
Propeller efficiency					
Rotation Rate/r/s					
Delivered Power/kW					

9 Validation assessment of numerical calculation method

(A detailed description of the numerical method used to demonstrate the rationality of the numerical results.)

Attachment 1 Lines and parameter comparison between XXX (vessel name) and YYY (vessel name)

Attachment 2 Numerical calculation report of YYY (vessel name)

Attachment 3 Comparison and analysis results of YYY (vessel name) numerical calculation results and model test results (including the calculation of calibration factor)

Attachment 4 (Supporting document text-1)

Attachment 5 (Supporting document text-2)

...

Attachment X (Supporting document text-X)